



## VRS-Needle Scalers

### Vibration Reduced Scalers

### Operations & Maintenance

VRS019NS  
VRS019CS  
VRS019NPG  
VRS019CPG  
VRS028NPG  
VRS028CPG  
19NSVSE105  
19NSVSE110  
28NSVSE110



[www.Novatekco.com](http://www.Novatekco.com)

© Copyright 2014 by NOVATEK Corporation

All rights reserved printed in the United States of America. No part of this manual may be used or reproduced in any form or by any means, stored in data base or retrieval system, without prior written permission from NOVATEK Corporation.

Making copies of this manual for any purpose other than your own personal use is a violation of the United States copyright laws.

March 1, 2016 issue 1.0

**Specifications subject to changes without notice!**

If you have any questions, please contact us:

NOVATEK CORORATION

700 Schell Lane

Phoenixville, PA 19460

USA

[www.novatekco.com](http://www.novatekco.com)

Toll Free 866 563-7800

Telephone: +1 610 363-7800

Fax +1 610 363-9620

Email: [Sales@Novatekco.com](mailto:Sales@Novatekco.com)

# OPERATION AND MAINTENANCE MANUAL FOR

## VIBRATION REDUCED NEEDLE SCALERS

### NOTICE

FOR PROFESSIONAL USE ONLY



### WARNING



**IMPORTANT SAFETY INFORMATION ENCLOSED.  
READ AND UNDERSTAND THIS MANUAL BEFORE OPERATING THIS PRODUCT.**

**IT IS YOUR RESPONSIBILITY TO MAKE THIS SAFETY INFORMATION  
AVAILABLE TO OTHERS THAT WILL OPERATE THIS PRODUCT.**

**FAILURE TO OBSERVE THE FOLLOWING WARNING COULD RESULT IN INJURY.**



### PLACING TOOL IN SERVICE

- Always install, operate, inspect and maintain this product in accordance with all applicable standards and regulations (local, state, country, federal, etc.).
- Compressed air models always use clean, dry air at 90 psi (6.19ar/620kPa) maximum air pressure at the inlet. Higher pressure may result in hazardous situations including excessive speed, rupture, or incorrect output torque or force.
- Electric models must always utilize proper gauge, and rated electrical cords with correct connections.
- Be sure all hoses and fittings are the correctly sized and secured.
- Ensure an accessible emergency shut off has been installed in the air or electrical supply line. Make others aware of its location.
- Do not use damaged, frayed, or deteriorated air hoses and fittings.
- Always use proper gauge electrical cords with correct connections. (When applicable.)
- Electric models must not use damaged, frayed, or deteriorated electrical cords and connections.
- Keep clear of whipping air hoses. Shut off the compressed air before approaching a whipping hose.
- Always turn off and disconnect the tool from its power supply before installing, removing or adjusting any accessory, or before performing any maintenance on the tool.
- Do not lubricate tools with flammable or volatile liquids such as kerosene, diesel or jet fuel. Use only recommended lubricants.
- Keep work area clean, uncluttered, ventilated and illuminated.
- Keep all electrical connections clear of water or other liquids. (When applicable.)
- Do not operate the machine while flammable or volatile liquids such as gasoline, diesel or jet fuel are present. Failure to do so can result in explosion. (When applicable.)
- Do not remove any labels. Replace any damaged label.

### USING THE TOOL

- Always wear protection when operating or performing maintenance on this tool.
- Always wear hearing protection when operating this tool.
- Always use Personal Protective Equipment appropriate to the tool used and material worked. This may include dust mask or other breathing apparatus, safety glasses, ear plugs, gloves, apron, safety shoes, hard hat and other equipment,
- Prevent exposure and breathing of harmful dust and particles created by power tool use:
  - Some dust created by power sanding, sawing, and grinding, drilling, and other construction activities contains chemicals known to cause cancer, birth defects or other reproductive harm. Some examples of these chemicals are:
    - Lead from lead based paints,
    - Crystalline silica from bricks and cement and other masonry products, and
    - Arsenic and chromium from chemically treated lumber
- Your risk from these exposures varies, depending on how often you do this type of work. To reduce your exposure to these chemicals: work in a well ventilated area, and work with approved safety equipment, such as those dust masks that are specially designed to filter out microscopic particles.
- Keep others a safe distance from your work area, or ensure they use appropriate Personal Protective Equipment.
- This tool is not designed for working in explosive environments, including those caused by fumes and dust, or near flammable materials.

- Electrically powered tools are not insulated against electric shock.
- Be aware of buried, hidden or other hazards in your work environment. Do not contact or damage cords, conduits, pipes, or hoses that may contain electrical wires, explosive gases or harmful liquids.
- Keep hands, loose clothing, long hair and jewelry away from working end of tool.
- Power tools can vibrate in use. Vibration, repetitive motions or uncomfortable positions may be harmful to your hands and arms. Stop using any tool if discomfort, tingling feeling or pain occurs. Seek medical advices before resuming use.
- Keep body stance balanced and firm. Do not overreach when operating this tool. Anticipate and be alert for sudden changes in motion, reaction torques, or forces during startup and operation.
- Tool and/or accessories may briefly continue their motion after throttle is released,
- To avoid accidental starting – ensure tool in “off” position before applying air pressure or connecting to electricity. Avoid throttle when carrying, and release throttle with loss of air or electricity.
- Ensure work pieces are secure. Use clamps or vises to hold work piece whenever possible.
- Do not carry or drag the tool by the hose or power cord.
- Do not use power tools when tired, or under the influence of medication, drugs, or alcohol.
- Never us a damaged or malfunctioning tool or accessory,
- Do not modify the tool, safety devices, or accessories.
- Do not use this tool for purposed other than those recommended.
- Use accessories recommended by Novatek Corp.
- Never operate a tool with an accessory unless it is properly installed and the tool is held firmly against the work,
- Always use a retainer, when furnished, in addition to proper barriers to protect persons in surrounding or lower areas from possible ejected accessories.
- When wearing gloves and operating models with inside trigger, always be sure that the gloves will not prevent the trigger from being released.
- Wear safety shoes, hard hat, safety goggles, gloves, dust mask and any other appropriate protective clothing while operating the tool.
- Do no indulge in horseplay. Distraction can cause accidents.
- Keep hands and fingers away from the throttle lever until it is time to operate the tool.
- Never rest the tool on your foot.
- Never point the tool at anyone.
- Compressed air is dangerous. Never point an air hose at yourself or others.
- Never blow clothes free of dust with compressed air.
- Be sure all hose connections are tight. A loose hose not only leaks but can come completely off the tool and while whipping under pressure, can injure the operator and other in the area. Attach safety cables to all hoses to prevent injury in case a hose is accidentally broken.
- Never disconnect a pressurized air hose. Always turn off the air supply and bleed the tool before disconnecting a hose.
- When applicable, the operator must keep limbs and body clear of the chisel. If a chisel breaks, the tool with the broken chisel projecting from the tool will suddenly surge forward.
- Do not ride the tool with one leg over the handle. Injury can result if the chisel breaks while riding the tool.
- Know what is underneath the material being worked. Be alert for hidden water, gas, sewer, telephone or electric lines.
- Use only proper cleaning solvents to clean parts. Use only cleaning solvents which meet current safety and health standards. Use cleaning solvents in a well ventilated area.
- Do not flush the tool or clean any parts with diesel fuel. Diesel fuel residue will ignite in the tool when the tool is operated, causing damage to internal parts. When using models with outside triggers or throttle levers, take care when setting the tool down to prevent accidental operation.
- Do not operate the tool with broken or damaged parts.
- Never start the tool when it is lying on the ground.
- This tool is not designed for working in explosive atmospheres.



## SECTION I

### GENERAL

This operation and maintenance manual is for Vibration Reduce Needle Scalers. Part numbers VR19NPG, VR28NPG and VR19NS.

### **READ ALL INSTRUCTIONS AND DATA IN THIS OPERATION AND MAINTENANCE MANUAL PRIOR TO OPERATION OF THIS EQUIPMENT.**

These instructions are for your protection and convenience. Please read them carefully since failure to follow the precautions could result in injury. Whenever using electric powered equipment, basic safety precautions should be followed.

If after reading this manual anything seems unclear, contact a **NOVATEK** authorized distributor or **NOVATEK** directly by dialing 1-866-563-7800.

## SECTION II

### PRIOR TO USE

1. Put a few drops of oil through the air inlet using light machine oil. (See recommended lubricants.)
2. The compressed air should be free from moisture and contamination. The installation of a filter/regulator/lubricator air preparation set (with moisture trap) is strong recommended.
3. Ensure that only 10mm (3/8") bore airline is used and that all Couplings are tight and in good condition.
4. Limit the length of airline to 50ft. Where extra length is necessary, for each additional 100ft, the pressed drop is approximately 0.19ar at 6.9bar.
5. Check that the tool is mechanically sound and all airlines are leak free and in good condition.

## SECTION III

### IN USE

1. Maintain contact with the work surface with sufficient pressure only to keep the tool from bouncing off. Excessive operator pressure will not improve tool efficiency. Handled in this way, the tool will cover a greater area more effectively leaving a more regular finish on the surface.
2. In particularly cold temperatures it is recommended that propriety anti-freeze lubricating oil is to be used.
3. Avoid letting the operating pressure fall below 5.5bar (80psi) or rise about 6.9bar (100psi).

**NOTE: The correct operating pressure is 6.19ar (90psi).**

## SECTION IV

### CHANGING NEEDLES

1. Before changing or replacing needles, disconnect the air supply to the tool.
2. Unscrew the Front Tube Assembly and remove the Front Assembly. Make sure to keep the Tube Assembly tilted down to not have internal components fall out.

**NOTE: Take note of how all parts within the front tube fit together as incorrect assembly will result in damaging the tool when used.**

3. Remove the Needle Holder from the Front Tube and change the Needles. Ensure that all Needles are replaced with new ones.
4. Place the Needle Holder back into the Front Tube assembly. Ensure that the Spring is in position and Needles are passing through the center. Refit the Front Tube assembly onto the body and tighten.

### **LUBRICATION**



Oil the tool daily during use, applying a few drops of light machine oil through the air inlet. Do not allow oil to enter and perish the air hose. Check the table below for recommended lubricants. Always use clean air tool oil from a sealed container if possible. The use of a filter lubricator in the airline of the tool is also strongly recommended. This will ensure trouble free running and prolong the life of the tool.

### **CLEANING**

At 100 hours of operating intervals or earlier if the operating becomes sluggish or tools show sign of sticking, flush through with a suitable solvent. Immediately after flushing, thoroughly oil the tool with one of the recommended lubricants.

**Note: Replace the 6mm Ball at this time.**

**VRS Needle/Chisel Guns and Accessories**

			
<b>VRS 19 Inline</b>	<b>VRS 19PG</b>	<b>VRS 28PG</b>	
<b>Part No.</b>	<b>Part No.</b>	<b>Part No.</b>	
Needle Scaler including Straight Front Tube and Chisel Tip Needles	VRS190NS	VRS019NPG	VRS028NPG
Chisel Scaler including 1/2" Square Chisel Holder and 3/4" Chisel	VRS190CS	VRS019CPG	VRS028CPG
VSE Vacuum Shrouded Needle Scaler w/ Chisel Tip Needles	19NSVSE105	19NSVSE110	28NSVSE110

**Needle Scaler Spares**

<b>Item No.</b>	<b>Description</b>	<b>Inline Part No.</b>	<b>19PG Part No.</b>	<b>28PG Part No.</b>
1	Valve Cap	28NS501	28NS501	28NS501
2	Valve Cap 'O' Ring (Pack of 10)	28NS502	28NS502	28NS502
3	Valve Spring	28NS503	28NS503	28NS503
4	Valve Stem	28NS504	28NS504	28NS504
5	Valve Seat 'O' Ring (Pack of 10)	28NS505	28NS505	28NS505
6	Valve Body Assembly (comprises items 1-8)		28NS506	28NS506
7	Throttle Lever	28NS507	28NS507	28NS507
8	Roll Pin (Pack of 10)	28NS508	28NS508	28NS508
9	Rubber Grip		28NS518N	28NS518N
10	Cover Assembly 19/PG & 28/PG		VRS19410	VRS28410
10A	Cover Assembly Inline	VRS28410		
12	Guide Plate	VRS19412	VRS19412	VRS28412
13	Guide Plate Seal	VRS19413	VRS19413	VRS28413
14	Guide Plate O'Ring	28NS512	28NS512	28NS512
15	Cylinder	VRS19415	VRS19415	VRS28415
17	6mm Diameter Ball	VRS28417	VRS28417	VRS28417
18	Ball Retaining O'Ring	VRS28418	VRS28418	VRS28418
22	Intermediate Tube	VRS19422	VRS19422	VRS28422
23	Tube Sleeve	VRS19423	VRS19423	VRS28423
24	Circlip			VRS28424
25	Front Tube Locking O'Ring	28NS512	28NS512	28NS512
26	Piston	VRS19426	VRS19426	VRS28426
28	Valve Pin	VRS28428	VRS28428	VRS28428
29	Piston Ring	VRS19429	VRS19429	VRS28429
30	3mm Needle Holder	VRS19431	VRS19431	VRS28431
30	2mm Needle Holder	VRS19430	VRS19430	VRS28430
31	Needles see item 31			
32	Front Spring	VRS19432	VRS19432	VRS28432
33	Front Tube Insert	VRS19433	VRS19433	VRS28433
34	Front Tube	VRS19434	VRS19434	VRS28434
35	Cylinder Stem Reaction Ring	VRS28435	VRS28435	VRS28435
36	Anvil ( Required Part to Run Chisel Holder )	VRS19436	VRS19436	VRS28436
37	Chisel Holder (Anvil Required to Run Chisels)	VRS19437	VRS19437	VRS28437
38	Chisels ( SEE PAGE 11 )			
	<b>Service Kit ( 2, 5, 13, 14, 17, 18, 19, 28, 29, 30, 31set &amp; 32</b>	<b>VRS19RK3</b>	<b>VRS19RK3</b>	<b>VRS28RK3</b>
40	VSE Vacuum Shrouded Tube	VRS28434VSE	VRS28434VSE	VRS28434VSE
41	Cap Head Screw	28NS530	28NS530	28NS530
42	Flat Cuff for flat Surface	19NSVSE401	19NSVSE401	28NSVSE401
43	Corner Cuff for inside and outside corners	19NSVSE402	19NSVSE402	28NSVSE402

**Needle Scaler Consumables**

Item	Description	Part No.
No.		
	<b>Carbon Steel</b>	
31	Pack of 100 2mm Needles (Flat Tip)	NPK2010
31a	Pack of 250 2mm Needles (Flat Tip)	NPK2015
311	Pack of 500 2mm Needles (Flat Tip)	NPK2020
31c	Pack of 2000 2mm Needles (Flat Tip) <b>Bulk Case</b>	NB27FCS
31d	Pack of 100 3mm Needles (Flat Tip)	NPK3040
31e	Pack of 250 3mm Needles (Flat Tip)	NPK3045
31f	Pack of 500 3mm Needles (Flat Tip)	NPK3050
31g	Pack of 1000 3mm Needles (Flat Tip) <b>Bulk Case</b>	NB37FCS
31h	Pack of 100 3mm Needles (Chisel Tip)	NPK3120
31i	Pack of 250 3mm Needles (Chisel Tip)	NPK3125
31j	Pack of 500 3mm Needles (Chisel Tip)	NPK3130
31k	Pack of 1000 3mm Needles (Chisel Tip) <b>Bulk Case</b>	NB37CCS
31p	Pack of 100 4mm Needles (Flat Tip)	NPK4010
31q	Pack of 250 4mm Needles (Flat Tip)	NPK4015
31r	Pack of 500 4mm Needles (Flat Tip) <b>Bulk Case</b>	NB47FCS
31s	Pack of 100 4mm Needles (Chisel Tip)	NPK4025
31t	Pack of 250 4mm Needles (Chisel Tip)	NPK4030
31u	Pack of 500 4mm Needles (Chisel Tip) <b>Bulk Case</b>	NB47CCS
31y	Pack of 50 3mm Needles (Beryllium Copper)	NPK3080
31z	Pack of 100 3mm Needles (Beryllium Copper)	NPK3085
31aa	Pack of 250 3mm Needles (Beryllium Copper)	NPK3090
31ab	Pack of 500 3mm Needles (Beryllium Copper) <b>Bulk Case</b>	NB37FBC
38	Chisel 1/2" Square 7" Long x 3/4" Blade	ACCS101
38a	Chisel 1/2" Square 7" Long x 2" Blade	ACCS103
38b	Chisel 1/2" Square 7" Long x Diamond Point	ACCS106
38c	Chisel 1/2" Square 10" Long x 3" Blade	ACCS107
38d	Chisel 1/2" Square Cranked 7" Long x 1 3/8" Blade	ACCS108
38e	Chisel 1/2" Square Spark Resistant Blade	ACCS110
	Allen Key for Cap Head Screws	H0601

**Number of Needles for Each Tool**

	2mm	3mm	4mm
<b>Inline</b>	51	19	
<b>19/PG</b>	51	19	
<b>28/PG</b>	65	28	19



# VRS 19 Inline Needle Scaler VSE

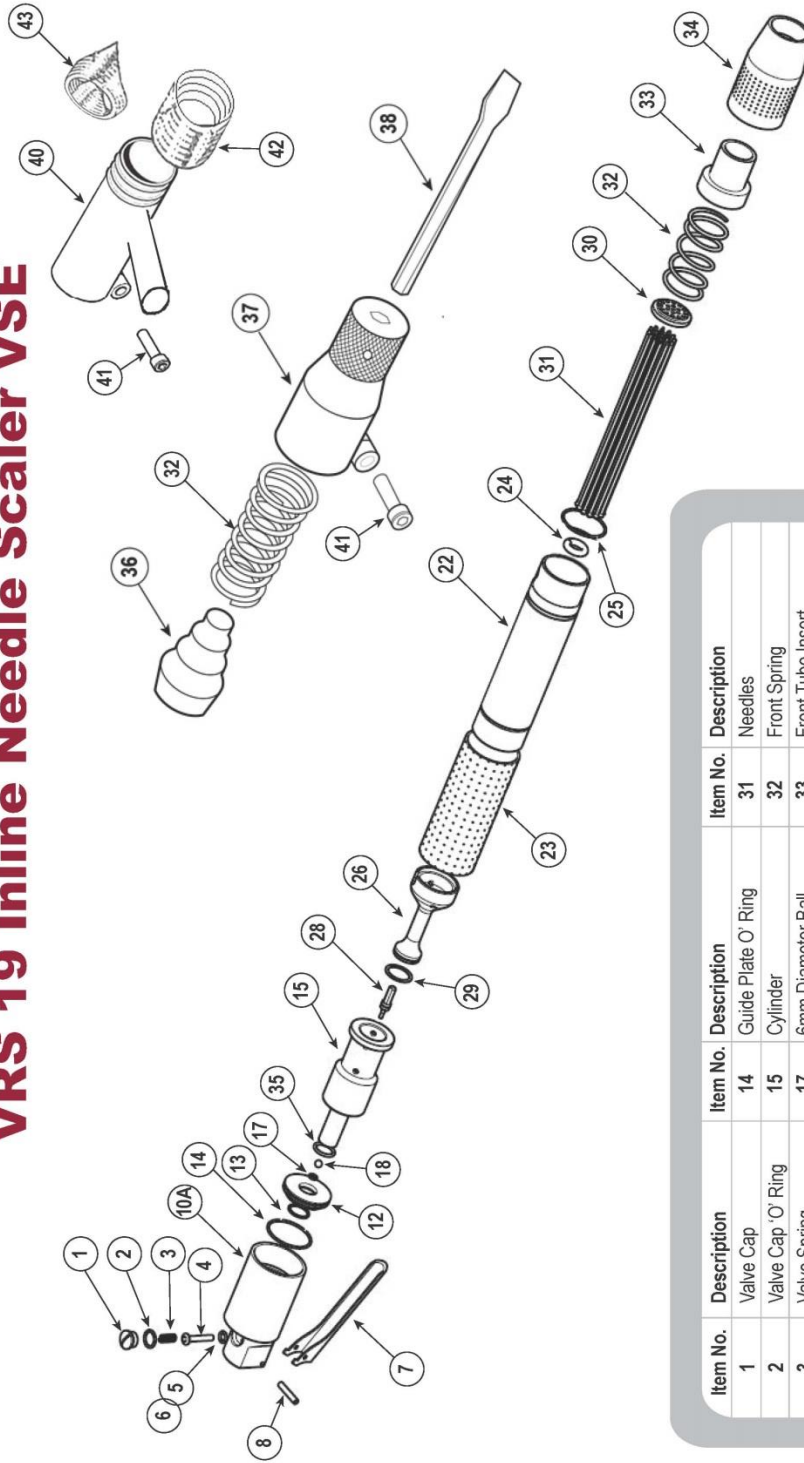

Item No.	Description	Item No.	Description	Item No.	Description
1	Valve Cap	14	Guide Plate O' Ring	31	Needles
2	Valve Cap 'O' Ring	15	Cylinder	32	Front Spring
3	Valve Spring	17	6mm Diameter Ball	33	Front Tube Insert
4	Valve Stem	18	Ball Retaining O'Ring	34	Front Tube
5	Valve Stem 'O' Ring	22	Intermediate Tube	35	Cylinder Stem Reaction Ring
6	Valve Body Assembly (Includes items: 1-8)	23	Tube Sleeve	36	Anvil (For Chisel Scaler)
7	Throttle Lever	24	Circle Clip	37	Chisel Holder
8	Roll Pin	25	Front Tube Locking O'Ring	38	Chisel
10A	Cover Assembly Inline	26	Piston	40	VSE Front Tube
12	Guide Plate	28	Valve Pin	41	Cap Head Screw
13	Guide Plate Seal	29	Piston Rings	42	Flat Cuff
		30	Needle Holder	43	Corner Cuff



# VRS 19 & 28 PG Needle Scaler VSE

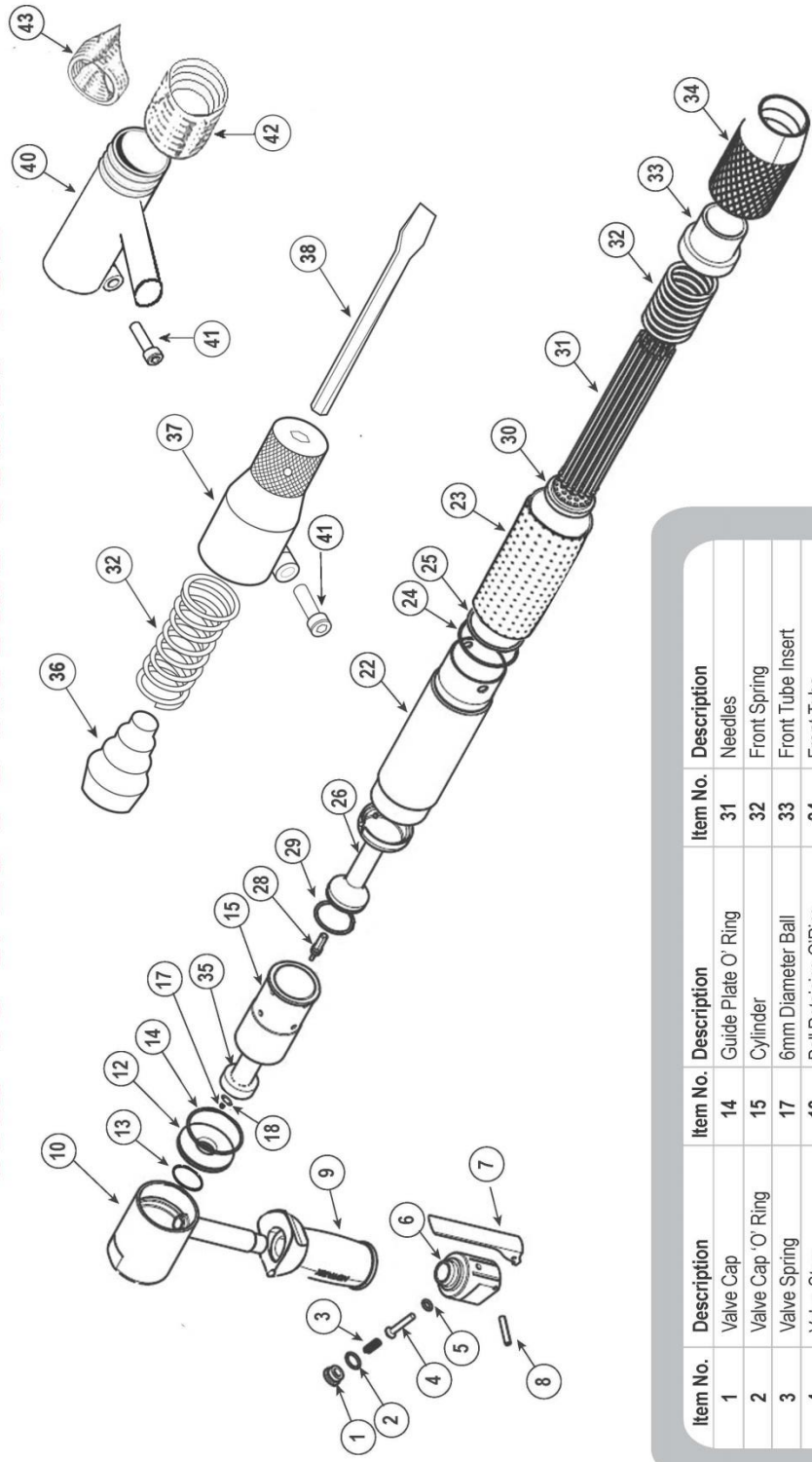

Item No.	Description	Item No.	Description	Item No.	Description
1	Valve Cap	14	Guide Plate O' Ring	31	Needles
2	Valve Cap O' Ring	15	Cylinder	32	Front Spring
3	Valve Spring	17	6mm Diameter Ball	33	Front Tube Insert
4	Valve Stem	18	Ball Retaining O'Ring	34	Front Tube
5	Valve Stem O' Ring	22	Intermediate Tube	35	Cylinder Stem Reaction Ring
6	Valve Body Assembly (Includes items: 1-8)	23	Tube Sleeve	36	Anvil (For Chisel Scaler)
7	Throttle Lever	24	Circlip	37	Chisel Holder
8	Roll Pin	25	Front Tube Locking O' Ring	38	Chisel
9	Rubber Grip	26	Piston	40	VSE Front Tube
10	Cover Assembly	28	Valve Pin	41	Cap Head Screw
12	Guide Plate	29	Piston Ring	42	Flat Cuff
13	Guide Plate Seal	30	Needle Holder	43	Corner Cuff



## NOVATEK CORPORATION LIMITED WARRANTY

The **TOOLS** manufactured by **NOVATEK CORPORATION** are warranted to be free from defects in material and workmanship for a period of **180 DAYS** from the date of purchase from **NOVATEK CORPORATION**. This warranty does not apply to accessories. All electrical components of the tool are also warranted to be free from defects in material and workmanship for a period of **180 DAYS**.

This warranty applies only to **TOOLS** purchased new from **NOVATEK CORPORATION**. This warranty does not apply to any **TOOL** which has been abused, misused, modified or repaired by someone other than **NOVATEK CORPORATION** or its authorized repair center.

If a **TOOL** proves defective in material or workmanship within one year of purchase from **NOVATEK CORPORATION**, it should be returned to **NOVATEK CORPORATION**, transportation pre-paid. The return must be authorized by a **RETURN MERCHANDISE AUTHORIZATION NUMBER (R.M.A. #)** obtained from **NOVATEK CORPORATION** prior to returning the **UNIT**. All packages must show clearly on the outside the return merchandise authorization number. All packages received without any R.M.A. # on the outside will be refused by **NOVATEK CORPORATION** receiving department.

Warranty claims will only be considered upon adequate proof of date of purchase. **NOVATEK CORPORATION** will, at its option, **REPAIR or REPLACE DEFECTIVE PARTS**. Repairs or replacements are warranted as above for the remainder of the original warranty period. The sole liability of **NOVATEK CORPORATION** and the user's exclusive remedy under this warranty is limited to the repair or replacement of the defective product.

THERE ARE NO OTHER WARRANTIES EXPRESSED OR IMPLIED AND **NOVATEK CORPORATION** SHALL NOT BE LIABLE FOR INCIDENTAL, CONSEQUENTIAL OR SPECIAL DAMAGES OR ANY OTHER EXPENSES OR REPAIR OR REPLACEMENT AS DESCRIBED ABOVE.

All warranty claims should be forwarded to:

**NOVATEK CORPORATION**  
**700 Schell Lane**  
**Phoenixville, PA 19460**

**ATTENTION: CLAIM AND SERVICE DEPARTMENT**  
**R.M.A. # \_\_\_\_\_**

**CALL Toll Free at 1-866-563-7800 for your RMA number prior to shipping.**

Also include a brief description of the problem as well as a phone number, contact name and return address in case **NOVATEK CORPORATION** service personnel has to get in contact with you.