

# KÄRCHER

makes a difference

## Chariot 2 iGloss 20

English

02

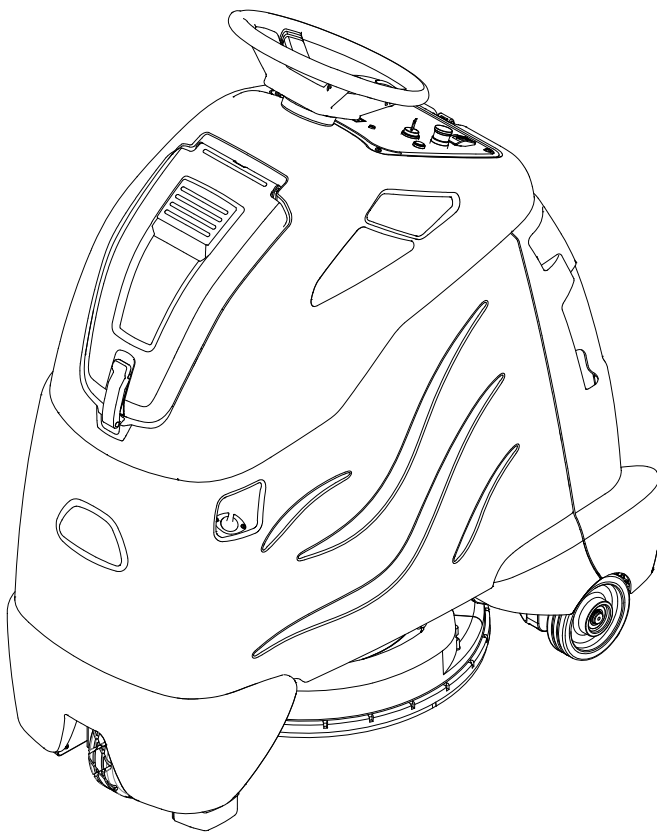

**Register  
your product**

[www.kaercher.com/welcome](http://www.kaercher.com/welcome)



86398800-D 12/16/19

## **Machine Data Label**

Model:	_____
Date of Purchase:	_____
Serial Number:	_____
Dealer:	_____
Address:	_____
Phone Number:	_____
Sales Representative:	_____

The Chariot iGloss 20 is a battery powered, ride-on, hard floor burnisher intended for commercial use. This machine applies a high luster to hard floor surfaces.

### **MODELS:**

**CBPS20** 1.002-031.0

**CBPSC20** 1.002-032.0

**CBPL20** 1.002-033.0

**CBPLC20** 1.002-034.0

**CBAL20** 1.002-035.0

**CBALC20** 1.002-036.0

### **Warranty Registration**

Thank you for purchasing a Kärcher North America product. Warranty registration is quick and easy. Your registration will allow us to serve you better over the lifetime of the product.

To register your product go to :

<http://warranty.karcherna.com/>

For customer assistance:

1-800-444-7654

**KÄRCHER**

makes a difference

**Machine Data Label** . . . . .2  
  Overview . . . . .2  
**Table of Contents** . . . . .3  
**How To Use This Manual** . . . . .4

**Safety**

IMPORTANT SAFETY INSTRUCTIONS . . . . .5  
HAZARD INTENSITY LEVEL . . . . .7  
SAFETY LABEL LOCATIONS . . . . .9

**Operation**

Technical Specifications . . . . .10  
How This Machine Works . . . . .12  
Components . . . . .13  
Drive Controls . . . . .14  
Function Mode Switch . . . . .18  
Pre-Run Machine Inspection . . . . .20  
Starting Machine . . . . .20  
Emergency Stop Procedure . . . . .20  
Operating the Machine . . . . .21  
Normal Burnishing . . . . .21

**Maintenance**

Service Schedule . . . . .22  
Checking Battery Specific Gravity . . . . .26  
Changing Batteries . . . . .28  
Battery Charger Programming . . . . .29  
Burnishing Pad . . . . .31  
Burnisher Motor Carbon Brush Ring Replacement .32  
Deck Actuator Removal / Replacement . . . . .32  
Body Assembly Removal . . . . .34  
Drive Unit Removal . . . . .34  
Vacuum - Optional . . . . .36  
Drive Motor-From Serial Number (3\*) . . . . .38  
Drive Motor Carbon Brush Replacement . . . . .38  
*Drive Chain Tension* . . . . .38  
Drive Motor-Prior to Serial Number (3\*) . . . . .40  
Drive Motor Carbon Brush Replacement . . . . .40  
*Drive Chain Tension* . . . . .40  
Machine Tie-Downs . . . . .42  
Troubleshooting . . . . .43  
Suggested Spare Parts . . . . .46

## How To Use This Manual

This manual contains the following sections:

- HOW TO USE THIS MANUAL
- SAFETY
- OPERATIONS
- MAINTENANCE
- PARTS LIST

The HOW TO USE THIS MANUAL section will tell you how to find important information for ordering correct repair parts.

Parts may be ordered from authorized Kärcher North America dealers. When placing an order for parts, the machine model and machine serial number are important. Refer to the MACHINE DATA box which is filled out during the installation of your machine. The MACHINE DATA box is located on the inside of the front cover of this manual.

Model:	_____
Date of Purchase:	_____
Serial Number:	_____
Dealer:	_____
Address:	_____
Phone Number:	_____
Sales Representative:	_____

The model and serial number of your machine are located below the battery compartment of the machine.

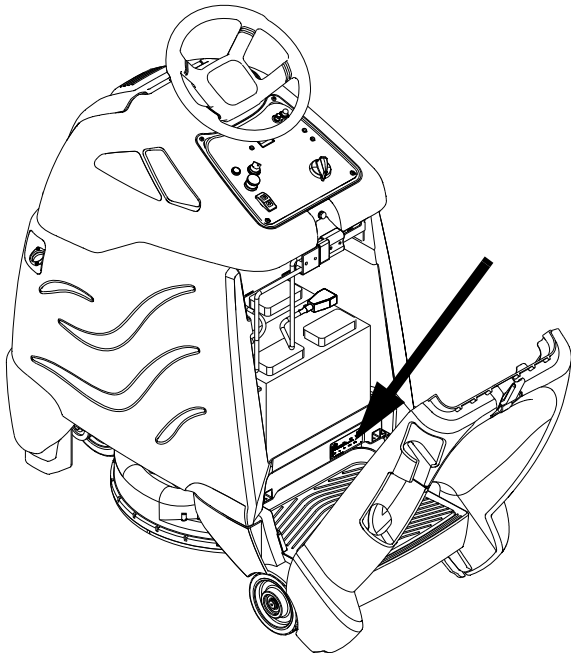

The SAFETY section contains important information regarding hazard or unsafe practices of the machine. Levels of hazards are identified that could

result in product or personal injury, or severe injury resulting in death.

The OPERATIONS section is to familiarize the operator with the operation and function of the machine.

The MAINTENANCE section contains preventive maintenance to keep the machine and its components in good working condition. They are listed in this general order:

- Batteries
- Brush Deck
- Circuit Protection
- Drive Motor and Brake
- Service Schedule
- Vacuum Motor
- Machine Troubleshooting

*The number on the lower right corner of the front cover is the part number for this manual.*



## **IMPORTANT SAFETY INSTRUCTIONS**

**When using an electrical appliance, basic precaution must always be followed, including the following:**

**READ ALL INSTRUCTIONS BEFORE USING THIS MACHINE.**

**⚠ WARNING:** To reduce the risk of fire, electric shock, or injury:

Use only indoors. Do not use outdoors or expose to rain.

Use only as described in this manual. Use only manufacturer's recommended components and attachments.

If the machine is not working properly, has been dropped, damaged, left outdoors, or dropped into water, return it to an authorized service center.

Do not operate the machine with any openings blocked. Keep openings free of debris that may reduce airflow.

This machine is not suitable for picking up hazardous dust.

Do not operate this machine near flammable fluids, dust or vapors.

Maintenance and repairs must be done by qualified personnel.

Disconnect battery before cleaning or servicing.

Before the machine is discarded, the batteries must be removed and properly disposed of.

Make sure all warning and caution labels are legible and properly attached to the machine.

During operation, attention shall be paid to other persons, especially children.

Before use all covers and doors shall be put in the positions specified in the instructions.

When leaving unattended, secure against unintentional movement.

The machine shall only be operated by instructed and authorized persons.

When leaving unattended, switch off or lock the main power switch to prevent unauthorized use.

This appliance has been designed for use with the pads specified by the manufacturer. The fitting of other pads may affect its safety.

Do not use on surfaces having a gradient of over 10% (6 degrees).

## **SAVE THESE INSTRUCTIONS**

## MESURES DE SÉCURITÉ IMPORTANTES

Lors de l'utilisation d'un appareil à batteries, il est nécessaire de respecter systématiquement des mesures de sécurité de base, comme suit :

**PRENEZ NOTE DE TOUTES CES MESURES AVANT D'UTILISER CETTE MACHINE.**

**⚠ AVERTISSEMENT:** Pour réduire les risques d'incendie, de chocs électriques, ou de blessures :

N'utiliser cette machine qu'en intérieur. Ne jamais l'utiliser à l'extérieur ou dans la pluie.

Utiliser cet appareil conformément aux instructions du présent manuel uniquement. N'utiliser que les composants et les accessoires conseillés par le fabricant.

Lorsque la machine ne fonctionnant pas correctement, a fait l'objet d'une chute ou d'une détérioration, a été laissée à l'extérieur, est tombée dans l'eau, la retourner au centre de service agréé.

Ne pas opérer la machine lorsque les conduits de ventilation sont bloquées. Débarrasser les débris des conduits, car ils peuvent réduire l'écoulement d'air.

Cette machine n'est pas adaptée au ramassage de poussières dangereuses

Ne pas l'utiliser près de liquides, de poussières ou de vapeurs inflammables.

L'entretien et les réparations de la machine doivent être effectuées par un personnel qualifié.

Si de la mousse ou du liquide sort de la machine, la mettre hors tension immédiatement.

Déconnecter les batteries avant de nettoyer la machine ou de la soumettre à un entretien.

Avant de se débarrasser de la machine, il est nécessaire de retirer les batteries et de les jeter correctement.

S'assurer que toutes les plaques d'avertissement ou de précaution sont lisibles et fixées correctement sur la machine.

Durant la manoeuvre de la machine, prendre garde aux personnes environnantes et notamment aux enfants.

Avant l'utilisation de la machine, veiller à positionner tous les couvercles et portes comme indiqué dans les instructions.

Lorsque la machine est laissée sans surveillance, s'assurer qu'elle ne se déplace pas de manière accidentelle.

Cette machine ne doit être manoeuvrée que par un personnel expérimenté et qualifié.

Lorsque la machine est laissée sans surveillance, la mettre hors tension ou verrouiller l'interrupteur principal afin d'empêcher un emploi non autorisé.

Seuls les produits chimiques recommandés par le fabricant doivent être utilisés.

Cette machine a été conçue pour être utilisée avec des garnitures spécifiées par le fabricant.

L'utilisation d'autres garnitures peut affecter sa sûreté.

N'employez pas sur des surfaces ayant un gradient de plus de 10% (6 degrés).

## CONSERVER CES INSTRUCTIONS

The following symbols are used throughout this guide as indicated in their descriptions:

## HAZARD INTENSITY LEVEL

There are three levels of hazard intensity identified by signal words -**WARNING** and **CAUTION** and **FOR SAFETY**. The level of hazard intensity is determined by the following definitions:

### **WARNING:**

**WARNING** - Hazards or unsafe practices which COULD result in severe personal injury or death.

### **CAUTION:**

**CAUTION** - Hazards or unsafe practices which could result in minor personal injury or product or property damage.

**FOR SAFETY: To Identify actions which must be followed for safe operation of equipment.**

Report machine damage or faulty operation immediately. Do not use the machine if it is not in proper operating condition. Following is information that signals some potentially dangerous conditions to the operator or the equipment. Read this information carefully. Know when these conditions can exist. Locate all safety devices on the machine. Please take the necessary steps to train the machine operating personnel.

#### **FOR SAFETY:**

**DO NOT OPERATE MACHINE:**

Unless Trained and Authorized.

Unless Operation Guide is Read and understood.

In Flammable or Explosive areas.

In areas with possible falling objects.

#### **WHEN SERVICING MACHINE:**

Avoid moving parts. Do not wear loose clothing; jackets, shirts, or sleeves when working on the machine. Use Kärcher North America approved replacement parts.

### **WARNING:**

**Batteries emit hydrogen gas. Explosion or fire can result. Keep sparks and open flame away. Keep battery compartment open during charging. Keep sparks and flames away from the batteries. Do not smoke around batteries.**

### **WARNING:**

**Disconnect batteries before working on machine. Only qualified personnel should work inside machine. Always wear eye protection and protective clothing when working on or near batteries. Avoid skin contact with the acid contained in the batteries.**

### **WARNING:**

**Never allow metal to lie across battery tops.**

## **Safety**

Les symboles ci-dessous sont utilisés à travers ce manuel comme illustré dans leurs descriptions :

### **DEGRÉS DE RISQUES EN CAS DE DANGER**

Il existe trois degrés de risques identifiés par les termes signalétiques -AVERTISSEMENT et ATTENTION et POUR VOTRE SÉCURITÉ. Le degré de risque est défini de la manière suivante:

#### **⚠ AVERTISSEMENT:**

**AVERTISSEMENT** - Dangers ou méthodes dangereuses qui POURRAIENT provoquer de graves blessures ou entraîner la mort.

#### **⚠ ATTENTION:**

**ATTENTION** - Dangers ou méthodes dangereuses qui pourraient provoquer des blessures légères ou une détérioration du produit ou des biens immobiliers.

**POUR VOTRE SÉCURITÉ:** ce signe permet d'identifier les mesures de précaution à prendre pour assurer un bon fonctionnement du matériel.

Rendre compte immédiatement d'une défaillance ou d'une détérioration de la machine. Ne pas utiliser la machine si celle-ci ne fonctionne pas correctement. Lire soigneusement les informations ci-dessous signalant certains dangers potentiels pour l'opérateur de la machine. L'opérateur doit être absolument au courant de ces dangers potentiels. Localiser tous les dispositifs de sécurité sur la machine. Il est conseillé de prendre les mesures nécessaires pour former le personnel opérateur.

#### **POUR VOTRE SÉCURITÉ:**

**NE PAS MANOEUVRER LA MACHINE:**

Lorsqu'on n'est pas expérimenté ou qualifié.

Lorsque le guide d'utilisation n'est pas été lu ou compris.

Dans des zones inflammables ou explosives.

Dans des zones où des objets peuvent tomber.

#### **LORS DE L'ENTRETIEN DE LA MACHINE:**

Éviter les parties amovibles. Ne pas porter de vêtements amples, tels que des vestes, des chemises ou des vêtements avec manches lors de l'utilisation de la machine. Utiliser les pièces détachées Kärcher North America homologuées.

#### **⚠ AVERTISSEMENT:**

**Les batteries émettent le gaz d'hydrogène. L'explosion ou le feu peut résulter. Étincelles de subsistance et flamme nue loin. Compartiment de batterie de subsistance ouvert en chargeant. Étincelles et flammes de subsistance loin des batteries. Ne fumez pas autour des batteries.**

#### **⚠ AVERTISSEMENT:**

**Déconnecter les batteries avant de travailler sur la machine. La machine ne doit être confiée qu'à un personnel qualifié. Porter systématiquement des lunettes et des vêtements de protection lors d'une intervention sur les batteries ou aux alentours. Éviter tout contact de la peau avec l'acide contenu dans les batteries.**

#### **⚠ AVERTISSEMENT:**

**Ne jamais placer d'objets métalliques sur le dessus des batteries.**

## SAFETY LABEL LOCATIONS

These drawings indicate the location of safety labels on the machine. If at any time the labels become illegible, promptly replace them.

### EMPLACEMENT DE L'ÉTIQUETTE DE SÉCURITÉ

REMARQUE : Ces dessins indiquent l'emplacement des étiquettes de sécurité sur la machine. Si, à tout moment, les étiquettes deviennent illisibles, contactez votre représentant autorisé pour un remplacement rapide.

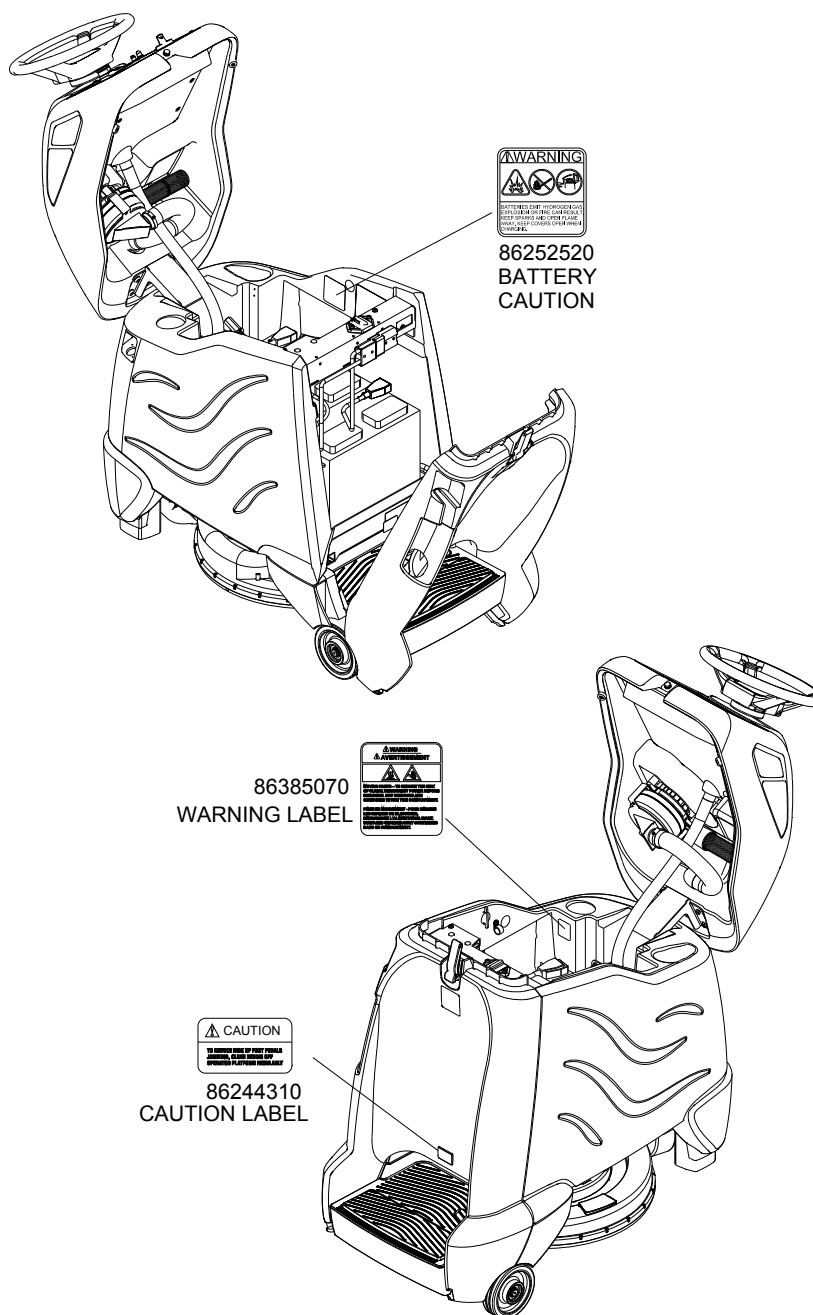

## Operation

### Technical Specifications

ITEM	DIMENSION/CAPACITY
Nominal Power	Passive Dust Control 2232W, Active Dust Control 2628W
Rated Voltage	36 Volts DC
Rated Amperage	Passive Dust Control 62A, Active Dust Control 73A
Batteries	3 X12 Volt 114 AH, 130 AH, 225AH, or 234AH @ 20 hr. rate
Battery Compartment Dimensions	21.5 in. x 15.25 in. x 16 in. tall (546mm x 387mm x 406mm tall)
Burnisher Motor	3.0 HP, 36V, 2000RPM (2237W)
Vacuum Motor	.63 HP (470 W)
Maximum flow rate of vacuum motor	72 cfm (33.98 liters per second)
Maximum suction of vacuum motor	47.3 inches of water (11.7 kPa)
Propelling Motor	.38 HP (280W)
Mass (GVW)	838 lbs (380 kg)
Weight empty without batteries	231 lbs (105 kg)
Burnisher pad diameter	20 inch (508 mm)
Tires	8 in. (203mm) drive, 6 in. (156mm) rear, polyurethane
Maximum Speed	2.3 mph (3.7Km/hour)
Theoretical Coverage	19,800ft <sup>2</sup> /hr @ 2.5 mph with 2 in. overlap
Brake	Electrical parking brake, sets automatically whenever operator stops.
Minimum aisle u-turn width	51in. (1295 mm)
Maximum rated climb and descent angle	10% (6 degrees)
Vibration, hands	1.58 m/s <sup>2</sup>
Vibration, feet	1.39 m/s <sup>2</sup>
Uncertainty	0.5 m/s <sup>2</sup>
Sound pressure level	Passive Dust Control 59.7 dBA, Active Dust Control 62.2 dBA
Sound power level	Passive Dust Control 76.3 dBA, Active Dust Control 80.1 dBA
Uncertainty	3.0 dBA

ITEM	MEASURE
Height	51.8 in (1316mm)
Length	44.0 in (1118mm)
Width	23.4 in. (594mm)
Width of burnish path	20 in (508mm)

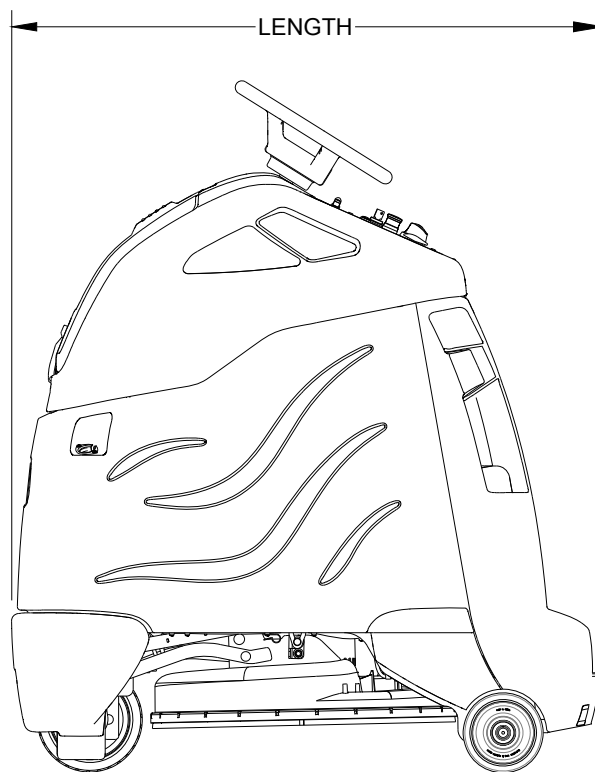
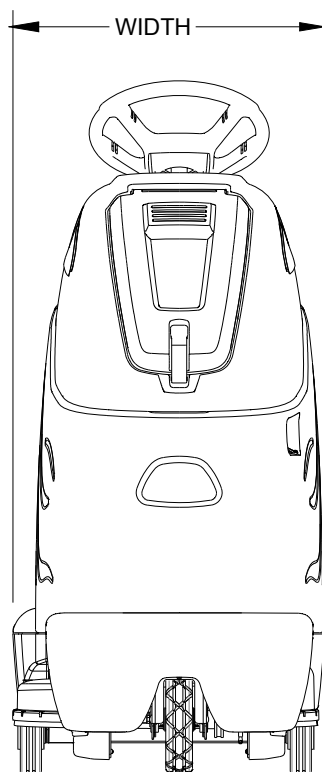

**⚠ CAUTION:**

This appliance is not intended for use by persons (including children) with reduced physical, sensory or mental capabilities, or lack of experience and knowledge, unless they have been given supervision or instruction concerning use of the appliance by a person responsible for their safety. Children should be supervised to ensure that they do not play with the appliance.

**⚠ ATTENTION:**

Cet appareil n'est pas prévu à l'usage des personnes (enfants y compris) avec des possibilités physiques, sensorielles ou mentales réduites, ou le manque d'expérience et de connaissance, à moins qu'ils aient été donnés la surveillance ou l'instruction au sujet de l'utilisation de l'appareil par une personne chargée de leur sûreté. Des enfants devraient être dirigés pour s'assurer qu'ils ne jouent pas avec l'appareil.

### **How This Machine Works**

The Chariot® iGloss 20 is a battery powered, self-propelled, hard floor burnisher intended for commercial use. The appliance spins a high-speed burnishing pad in contact with the floor surface to produce a high luster shine.

The machine's primary systems are the burnishing system, the dust control system, and the operator control system.

The function of the burnishing system is to spin a high-speed burnishing pad in contact with a floor surface that has had a burnishable floor finish applied. The burnishing pad can be lowered to the floor and raised by the operator. The burnishing pad will spin only when the machine is directed to move by the operator.

The function of the dust control system is to collect the dust that is created during the burnishing process. It is normal for a portion of the floor finish to be removed in the form of dust during the process. While burnishing, air movement is created within the burnishing head by the spinning pad. The dust that is also created is entrained in the air stream and transported to a filter bag where it is collected and separated from the air stream. The filter bag can be easily changed without releasing the collected dust. The optional active dust control system uses a vacuum motor to improve dust collection before, during, and after burnishing.

The function of the operator control system is to control the direction and speed of the machine. The directional control system consists of the direction control drive reset switch, throttle pedal, emergency stop/brake switch, steering wheel, propel controller, and drive wheel. The directional control drive reset switch signals forward or reverse direction and makes sure the operator is on the platform before machine will propel. The controller interprets signals from the throttle pedal to command the drive wheel to propel or slow the machine. The steering wheel points the drive wheel in the direction desired by the operator. The parking brake automatically engages when the operator stops the machine. The emergency stop/brake can be used to hold the machine on slopes.



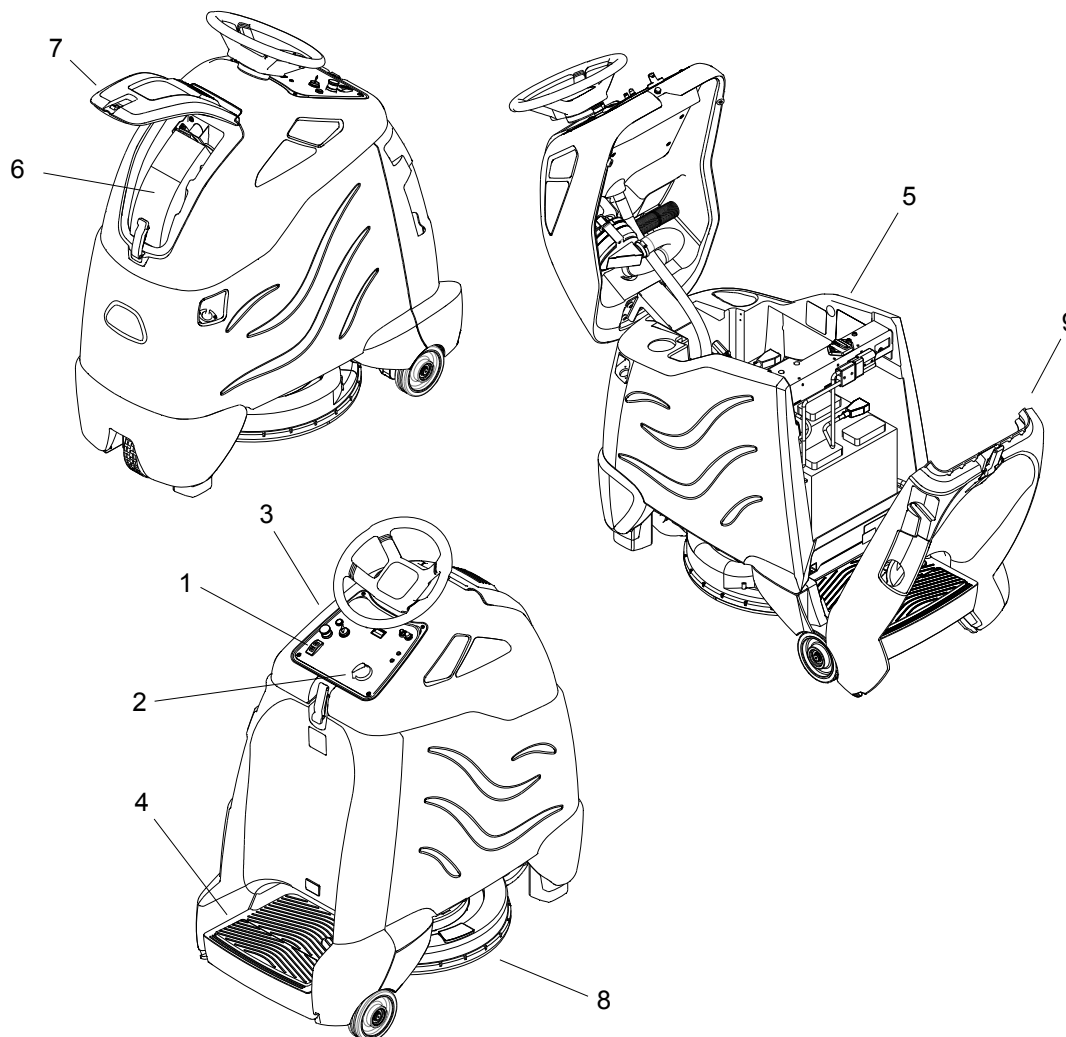

**Components**

- |                       |                        |
|-----------------------|------------------------|
| 1. Drive Control      | 6. Bag Enclosure       |
| 2. Burnisher Controls | 7. Bag Enclosure Cover |
| 3. Control Console    | 8. Burnisher Deck      |
| 4. Pedal Platform     | 9. Rear Cover          |
| 5. Lower Body         |                        |

# Operation

## Drive Controls

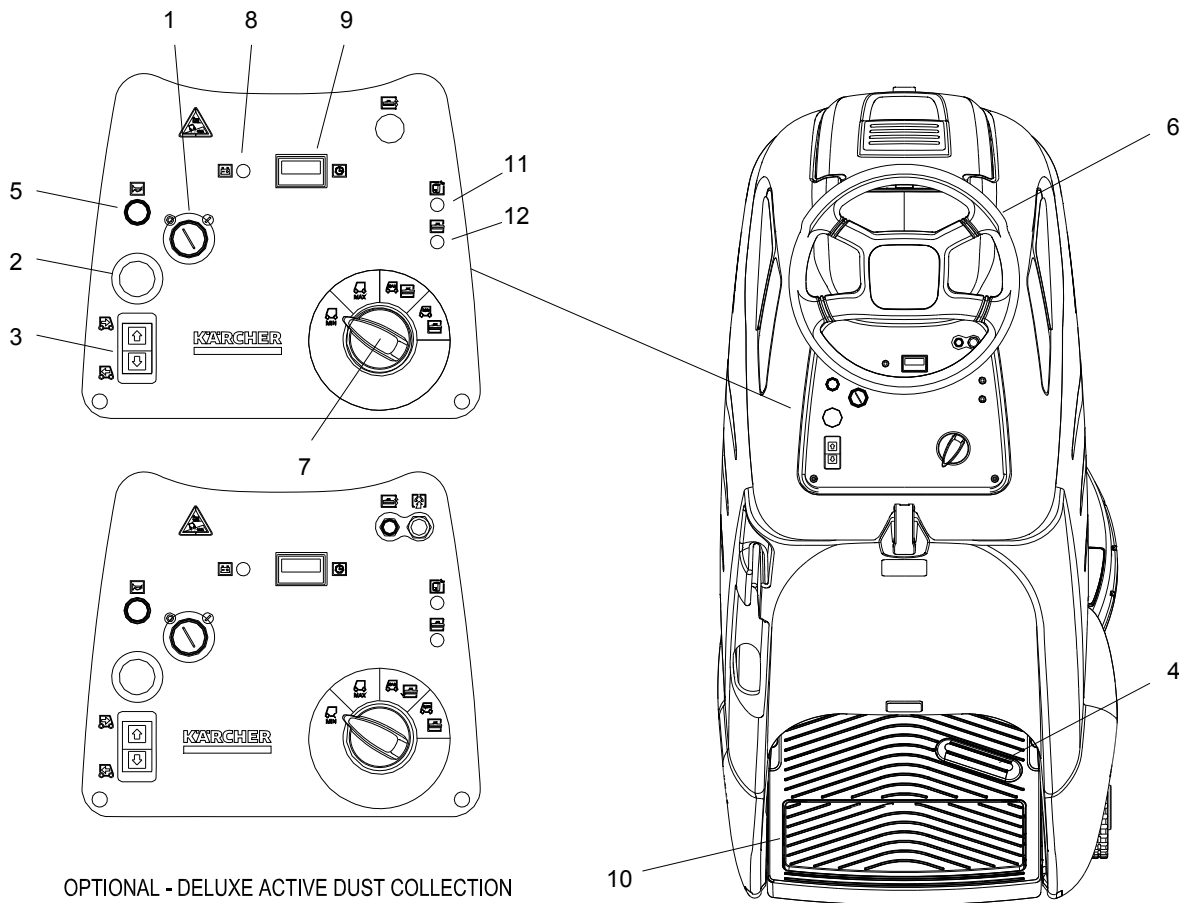

1. Key Switch
2. Emergency Stop/Brake Switch
3. Directional Control / Drive Reset Switch
4. Throttle Pedal
5. Horn Button
6. Steering Wheel
7. Speed Control/Function Select
8. Battery Discharge Indicator
9. Hour Meter
10. Operator Presence Switch
11. Bag Present indicator
12. Check Pad Indicator

**1. KEY SWITCH**

Controls the power for machine functions.

To turn the machine power on, rotate key clockwise.

To turn the machine off, rotate key counterclockwise.

When the key is turned on the battery symbol will flash once and stay on continuously.

**2. EMERGENCY STOP/BRAKE SWITCH**

This safety feature is designed to cut all power to the machine at any time and apply parking brake.

To shut the machine power off, push the Emergency Stop Switch, this will also engage the parking brake and cause the machine to stop immediately.

To reset the machine, rotate the switch clockwise.

**3. DIRECTIONAL CONTROL / DRIVE RESET SWITCH**

This safety feature is designed to ensure safe engagement of propel drive. Each time the machine power is turned on, or each time an operator steps on to the platform, the Drive Reset Switch must be pushed before machine will propel.

The switch controls the direction of travel of the vehicle. The lighted arrow on the switch indicates direction of travel.

To travel forward, press the top of the switch.

To travel in reverse, press the bottom of the switch.

## Operation

---

### 4. THROTTLE PEDAL

Controls the speed of the vehicle within the speed control setting selected. Pressing the pedal causes the machine to travel in the direction selected by the Directional Control Switch.

To increase speed, increase pressure on the pedal.

To decrease speed, decrease pressure on the pedal.

### 5. HORN BUTTON

The horn is activated by pressing the horn button.

### 6. STEERING WHEEL

The steering wheel turns the front wheel causing the machine to change direction.

### 7. SPEED CONTROL

Controls the maximum speed of the machine. There are two settings, slow and fast.

To change speed, rotate the dial to either slow or fast position. The slow position is to the left (counterclockwise), fast to the right (top position).

The throttle pedal will always regulate the speed between 0 and maximum

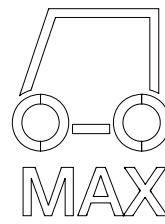
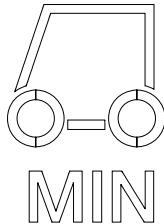

**8. BATTERY DISCHARGE INDICATOR**

Indicates the charge level of the batteries.

The indicator will be illuminated if the batteries have a sufficient charge. A slow, continuous flash indicates the batteries require charging.

The Battery Lockout function will activate when the batteries are low.

Once active, the LED status indicator will begin to flash slowly and the controller will inhibit the burnisher motor.

The vacuum and drive remain functional. Return the unit to the charging station and charge the batteries.

*NOTES: Continuing usage may damage the batteries.*

When the machine is left overnight with less than a full charge, the display may initially indicate a full charge. It will also indicate a full charge if the batteries are disconnected, then reconnected. After a few minutes of operation the indicator will give the correct charge level.

**9. HOUR METER**

Records the number of hours the machine has been in burnishing operation. This information is useful in determining when to service the machine.

**10. OPERATOR PRESENCE SWITCH**

Must be pressed down prior to any machine functions enabled.

**11. BAG PRESENT INDICATOR**

Notifies operator if dust collection bag is missing. LED is red when bag is missing or not properly installed.

**12. CHECK PAD INDICATOR**

Notifies operator of potential problem with pad or missing pad. When LED is red, operator should remove pad driver and verify pad condition and proper installation.

## Function Mode Switch

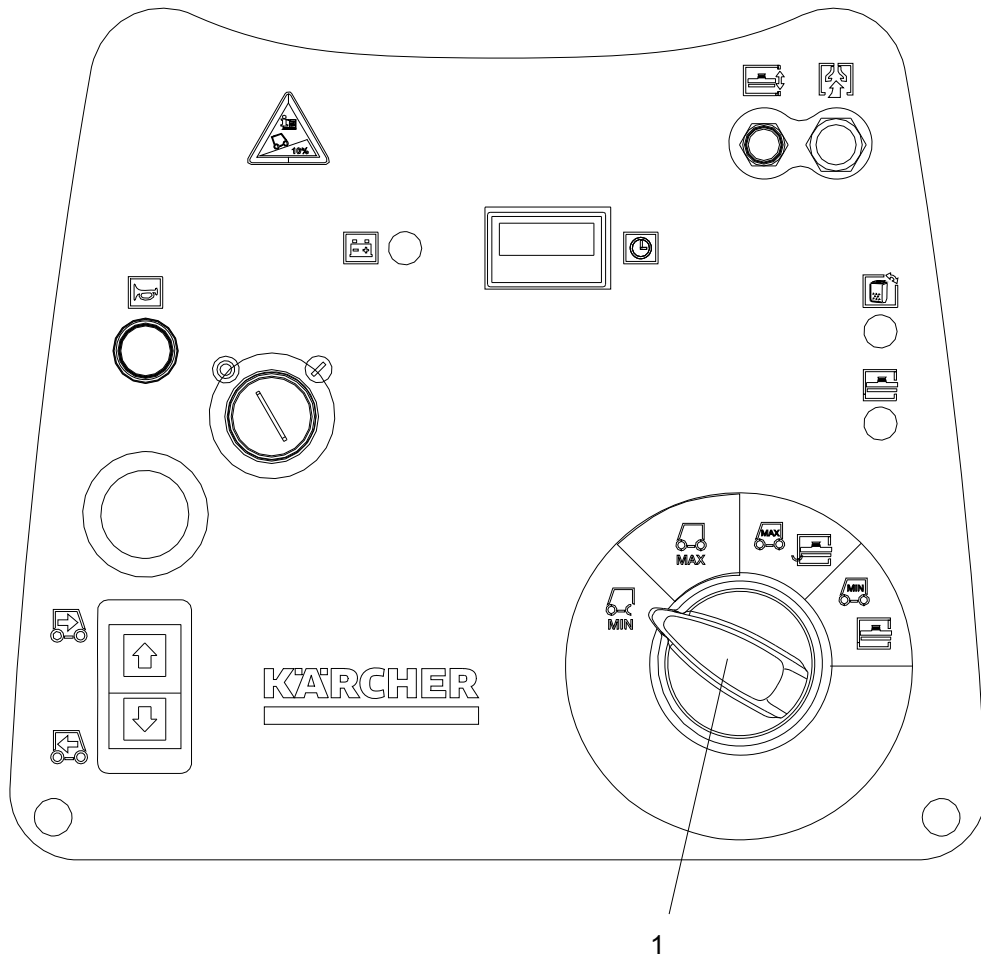

### 1. Function Mode Switch

The first two positions are for transport only. See drive controls section.

#### Light burnishing



This mode is used for light burnishing. In this mode the machine will propel at fast speed. The 'floating' burnisher deck is in the down position. When equipped with optional active dust collection, vacuum motor will be on.

#### Deep burnishing



This mode is used for deep burnishing. In this mode the machine will propel at slow speed. The 'floating' burnisher deck is in the down position. When equipped with optional active dust collection, vacuum motor will be on.



## **Operation**

---

### **Machine Operation**

#### **Pre-Run Machine Inspection**

Do a pre-run inspection to find possible problems that could cause poor performance or lost time from break-down. Follow the same procedure each time to avoid missing steps.

*NOTE: See maintenance section for pre-run machine inspection checklist items.*

#### **Starting Machine**

*NOTE: Perform pre-run machine check before operating machine.*

**FOR SAFETY: Before starting machine, make sure that all safety devices are in place and operating properly.**

1. Disconnect or unplug battery charger.
2. Close the cover(s).
3. Verify condition of burnishing pad, replace if necessary.
4. Verify removable pad driver is installed correctly and pad rotation lock is released.
5. The operator should be on the pedal platform. The throttle pedal must be in the neutral position.
6. Turn the machine power on by turning key switch clockwise to the "ON" position.
7. Verify dust collection bag is installed.
8. Press the Drive Reset Directional Control Switch to reset and set the intended direction for travel.
9. Press lightly on the throttle pedal with right foot

#### **Emergency Stop Procedure**

Push in emergency stop button. This will also engage the parking brake and cause the machine to stop immediately.



## Operating the Machine

When operating the machine around people, pay close attention for unexpected movement. Use extra caution around children.

1. Stand on the operator platform. Throttle pedal must be in neutral position.
2. Turn machine power on.
3. Select transport speed from Function Mode Switch.
4. Press the Drive Reset/Directional Control Switch, selecting the desired travel direction.
5. Select Light burnishing or Deep burnishing from the Function Mode Switch. Deck will Lower.
6. The pad motor will only run when the burnishing head is lowered to within 2 inches of the floor.
7. Occasionally verify "check pad" indicator light is "green". If not, stop machine, remove pad driver and check pad. Replace or flip as needed.

*NOTE: To prevent possible damage to the floor surface, always keep the machine moving while the pad is spinning.*

8. When the head is down and the machine is propelled, the pad motor runs.
9. When the battery light flashes it indicates discharged batteries, stop operation and charge batteries.

## Normal Burnishing

Plan the burnishing pattern in advance. The longest track is around the perimeter of the area to be burnished. For efficient operation, the runs should be the longest possible without turning, stopping, or raising or lowering the burnisher head.

In order to achieve the best possible results, the area which is to be burnished should be swept and auto scrubbed before burnishing.

### INEFFICIENT BURNISHING PATH

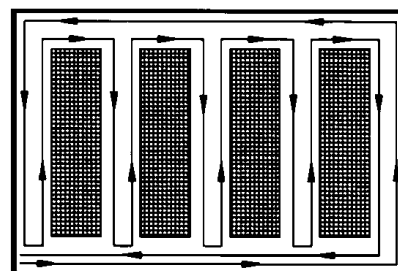

### RECOMMENDED BURNISHING PATH

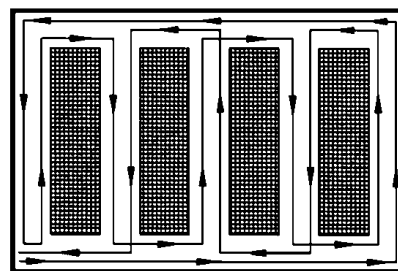

## Maintenance

### Service Schedule

MAINTENANCE	BEFORE EACH WORK PERIOD	AFTER EACH WORK PERIOD	50 HRS	100 HRS	200 HRS
Check water level of batteries after charging; add distilled water if necessary. (Wet cell only)	*				
Visually check for damaged or worn tires.	*				
Check brush or pad for proper installation.	*				
Check vacuum hose connections.	*				
Check pedal, brake and steering for proper operation.	*				
Check dust bag.		*			
Charge batteries if needed.		*			
Clean off top of batteries.			*		
Check battery cells with hydrometer. (Wet cell only)			*		
Inspect deck skirt.			*		
Check battery connections are tight.			*		
Clean battery cases and battery compartment.				*	
Check parking brake.					*
Clean pivot points on burnishing head.					*
Check all motors for carbon brush wear.					*
Check steering chain tension.					*
Check drive chain tension.					*

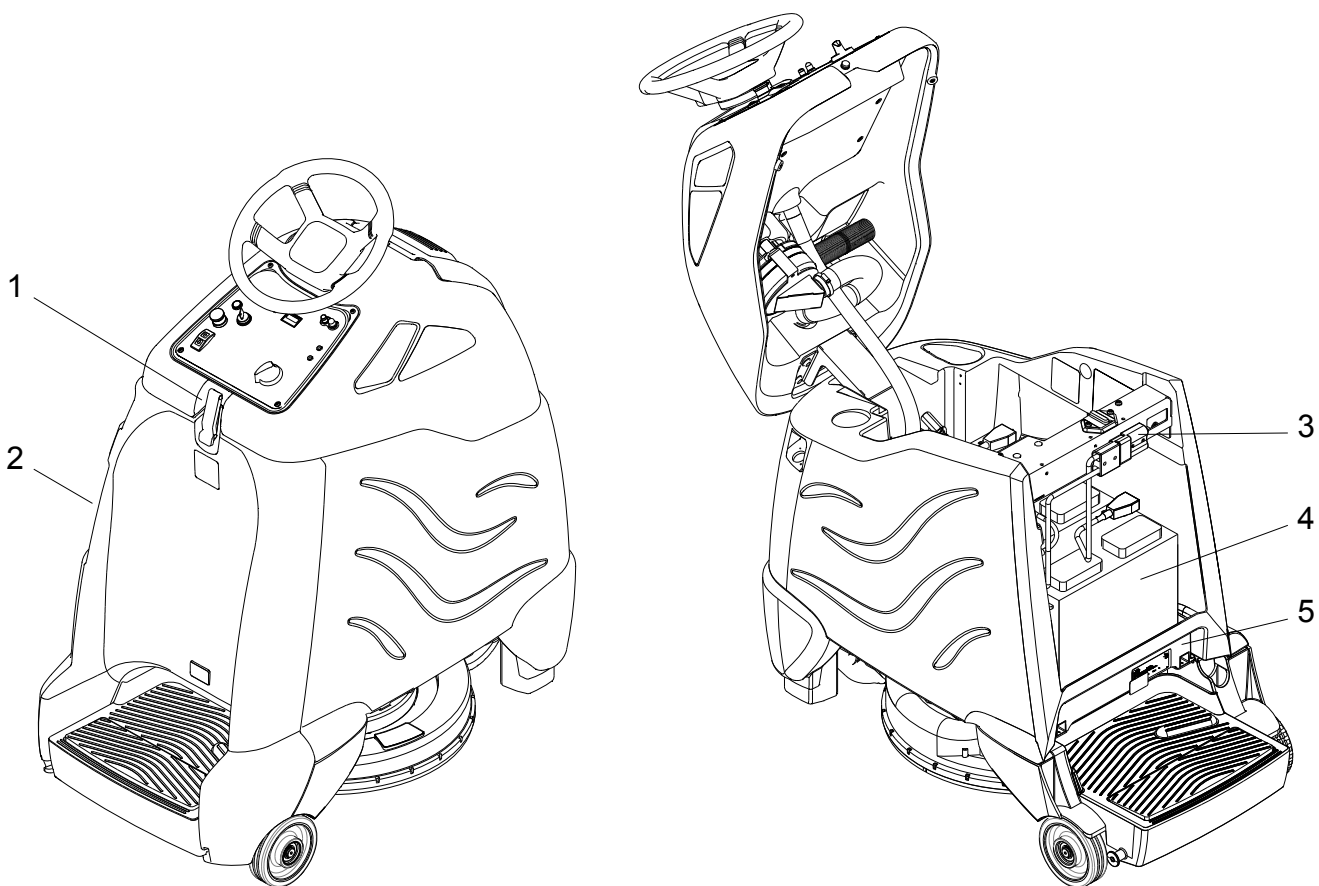

- 1. **Cover Retainer Latch**
- 2. **Rear Cover**
- 3. **Battery Connector-Machine**
- 4. **Batteries**
- 5. **Battery Tray**

### **Batteries (Wet Cell)**

The batteries provide the power to operate the machine. The batteries require regular maintenance to keep them operating at peak efficiency.

The machine batteries will hold their charge for long periods of time, but they can only be charged a certain number of times. To get the greatest life from the batteries, charge them when their charge level reaches 25% of a full charge. Use a hydrometer to check the charge level.

Do not allow the batteries to remain in a discharged condition for any length of time. Never expose a discharged battery to temperatures below freezing. Discharged batteries will freeze causing cracked cases. Do not operate the machine if the batteries are in poor condition or if they have a charge level below 25% (specific gravity below 1.155).

Keep all metallic objects off the top of the batteries, as they may cause a short circuit. Replace worn or damaged cables and terminals.

Check the electrolyte level in each battery cell before and after charging the batteries. Never add acid to the batteries, use distilled water. Do not allow water level to fall below the battery plates. Portions of plates exposed to air will be destroyed. Do not overfill. Keep plugs firmly in place at all times.

#### **⚠ WARNING:**

**Not all batteries require maintenance. AGM batteries are maintenance free. Do not attempt to remove sealed caps from AGM batteries. Warranty is void if caps are removed from AGM battery.**

#### **⚠ AVERTISSEMENT:**

**L'entretien n'est pas nécessaire pour toutes les batteries. Les batteries AGM ne nécessitent pas d'entretien. N'essayez pas d'enlever les bouchons scellés des batteries AGM. La garantie est annulée si les bouchons sont retirés des batteries AGM.**

**⚠ CAUTION:**

When servicing machine, avoid contact with battery acid.

**⚠ ATTENTION:**

Lors de l'entretien de la machine, évitez tout contact avec l'acide de batterie.

**⚠ WARNING:**

Batteries emit hydrogen gas. Explosion or fire can result. Keep sparks and open flame away. Keep covers open when charging.

**⚠ AVERTISSEMENT:**

Les batteries émettent du gaz hydrogène. Une explosion ou un incendie peut en résulter. Maintenez les étincelles et les flammes nues à l'écart. Gardez les carters ouverts lors du chargement.

**⚠ WARNING:**

Wear eye protection and protective clothing when working with batteries.

**⚠ AVERTISSEMENT:**

Portez des lunettes de protection et des vêtements de protection lorsque vous travaillez avec des batteries.

**⚠ WARNING:**

Charge batteries in a well ventilated area.

**⚠ AVERTISSEMENT:**

Chargez les batteries dans un endroit bien ventilé

**Battery Maintenance**

1. When cleaning the batteries, use a solution of baking soda and water. Do not allow the cleaning fluid to enter the battery cells, electrolyte will be neutralized.
2. Maintain the proper electrolyte level in each battery cell. If a cell should accidentally overflow, clean immediately.
3. Wipe off the top of the batteries at least once a week.
4. Test battery condition with a hydrometer at least once a week.
5. Ensure that all connections are tight and all corrosion removed.
6. Every 4 to 6 months, remove the batteries from the machine and clean the battery cases and battery compartment.

## Maintenance

### Checking Battery Specific Gravity

Use a hydrometer to check the battery specific gravity.

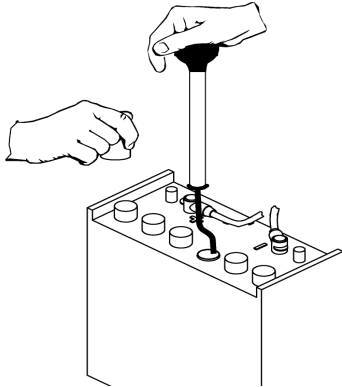

#### CHECKING GRAVITY

- a. Hydrometer Battery
- b. Battery

*NOTE: Do not take readings immediately after adding distilled water, if the water and acid are not thoroughly mixed, the reading may not be accurate.*

Check the hydrometer readings against this chart.

<b>SPECIFIC GRAVITY @ 80°F (27°C)</b>	<b>BATTERY CONDITION</b>
1.265	100% CHARGED
1.225	75% CHARGED
1.190	50% CHARGED
1.155	25% CHARGED
1.120	DISCHARGED

*NOTE: If the readings are taken when the battery electrolyte is any temperature other than 80°F (27°C), the reading must be temperature corrected.*

To find the corrected specific gravity reading when the temperature of the battery electrolyte is other than 80°F (27°C): Add (+) to the specific gravity reading 0.004 (4 points), for each 10°F (6°C) above 80° (27°C). Subtract (-) from the specific reading 0.004 (4 points), for each 10°F (6°C) below 80°F (27°C).

## Charging Batteries

### **⚠ CAUTION:**

When servicing machine, avoid contact with battery acid.

### **⚠ ATTENTION:**

Lors de l'entretien de la machine, évitez tout contact avec l'acide de batterie.

### **⚠ WARNING:**

Batteries emit hydrogen gas. Explosion or fire can result. Keep sparks and open flame away. Keep covers open when charging.

### **⚠ AVERTISSEMENT:**

Les batteries émettent du gaz hydrogène. Une explosion ou un incendie peut en résulter. Maintenez les étincelles et les flammes nues à l'écart. Gardez les carters ouverts lors du chargement.

### **⚠ WARNING:**

Wear eye protection and protective clothing when working with batteries.

### **⚠ AVERTISSEMENT:**

Portez des lunettes de protection et des vêtements de protection lorsque vous travaillez avec des batteries.

### **⚠ WARNING:**

Charge batteries in a well ventilated area.

### **⚠ AVERTISSEMENT:**

Chargez les batteries dans un endroit bien ventilé

Use a 36 volt, 20 amp maximum output DC charger which will automatically shut off when the batteries are fully charged.

1. Stop the machine in a clean, well ventilated area next to the charger.
2. Turn "OFF" machine.

*FOR SAFETY: Before leaving or servicing machine; stop on level surface, turn off machine and remove key.*

3. Remove rear cover, unplug batteries from machine.

### **⚠ WARNING:**

Batteries emit hydrogen gas. Explosion or fire can result. Keep sparks and open flame away. Keep covers open when charging.

### **⚠ AVERTISSEMENT:**

Les batteries émettent du gaz hydrogène. Une explosion ou un incendie peut en résulter. Maintenez les étincelles et les flammes nues à l'écart. Gardez les carters ouverts lors du chargement.

4. Check the electrolyte level in each battery cell. Before charging, add just enough distilled water to cover the plates. After charging is complete, add just enough distilled water to bring up the level to the indicator ring. If the water level is too high before charging, normal expansion rate of the electrolyte may cause an overflow resulting in a loss of battery acid balance and damage the machine.

## Maintenance

5. Replace the battery caps, and leave them in place while charging.
6. Unplug the battery connector from the machine.

**FOR SAFETY: When charging, connect the charger to the batteries before connecting the charger to the AC wall outlet. Never connect the charger to the AC wall outlet first. Hazardous sparks may result.**

7. Plug the charger connector into the battery connector. Connect the charger AC plug to a wall outlet. The charger gauge should indicate that the batteries are charging.
8. When the batteries are fully charged, disconnect the charger from the AC wall outlet, then disconnect the charger from the batteries.
9. Connect the batteries to the machine connector.
10. Check the electrolyte level. It should be up to the indicator ring. If necessary, add distilled water.
11. Install the rear cover.

### Changing Batteries

Stop the machine in a clean area next to the charger. Turn off machine.

**FOR SAFETY: Before leaving or servicing the machine; stop on level surface, turn off machine and remove key.**

1. Open the console cover.
2. Remove rear cover.
3. Disconnect battery pack from machine.

Use the proper size open end wrench to disconnect main ground wire first and secure cable terminal away from batteries.

4. Disconnect main positive lead and secure cable terminals away from batteries.
5. Loosen both terminals on each jumper cable and remove one at a time.
6. Prepare a suitable site to place the batteries.

### **⚠ WARNING:**

**Attach suitable battery lifting device and lift batteries from the machine. Batteries are a potential environmental hazard. Consult your battery supplier for safe disposal methods.**

### **⚠ AVERTISSEMENT:**

**Fixez le dispositif de levage de batterie approprié et levez les batteries de la machine. Les batteries constituent un danger potentiel pour l'environnement. Consultez le fournisseur de votre batterie pour connaître les méthodes d'élimination sûres.**

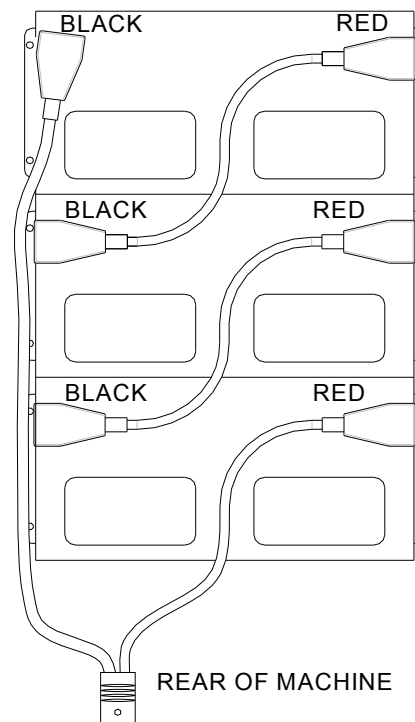

**NOTE: Red (+) and Black (-) installed opposite for 225 AH (J185) battery configuration.**



## Battery Charger Programming

*NOTE: For machines equipped with optional on-board charger. When replacing batteries, charger programming changes may be required. If replacing batteries with same type, (e.g. maintenance free batteries with maintenance free) no programming is required. When batteries with different type (e.g. maintenance free with wet cell), programming changes are required. Failure to make programming changes may lead to reduced battery life.*

## Programming Instructions

The charger is pre-loaded with the charge algorithms shown below:

AlgID	Description
1	Trojan J185H
5	Trojan 30XHS
42	Discover AGM EV31A-A
43	Discover AGM EV185A-A

## Check Default Charge Algorithm

Enter Algorithm Display Mode:

1. Disconnect AC Power.
2. Remove positive lead from battery pack.
3. Apply AC power and the charger will display the algorithm number after the Power On Self Test:
  - a. All algorithms will display as a series of flashes of the 80% LED.
  - b. Algorithms #1 - 6 will also be indicated by the Ammeter LEDs (see Users Guide).

Examples:

☼☼☼☼ = Algorithm #3

☼☼☼ , Short Pause, ☼ = Algorithm #21

4. Algorithm number display repeats for 11 seconds, then Algorithm Display Mode ends.
5. Remove AC Power and reconnect positive lead.

## Check Default Charge Algorithm

1. Enter Algorithm Display Mode (as above).
2. While Algorithm Number is displayed (for 11 seconds), touch positive lead to the battery pack positive terminal for 3.0 seconds (± 0.5s).
3. Remove lead from battery pack. Algorithm Number will increment.
4. To increment the Algorithm Number again, repeat Steps 2 and 3 within 30 seconds.
5. Touch positive lead to positive terminal and hold until relay clicks (>10 seconds). The new default algorithm is now stored.
6. Remove AC power and check default algorithm.

Contact your original equipment manufacturer if your battery pack is not supported by the charge algorithms loaded in your charger.

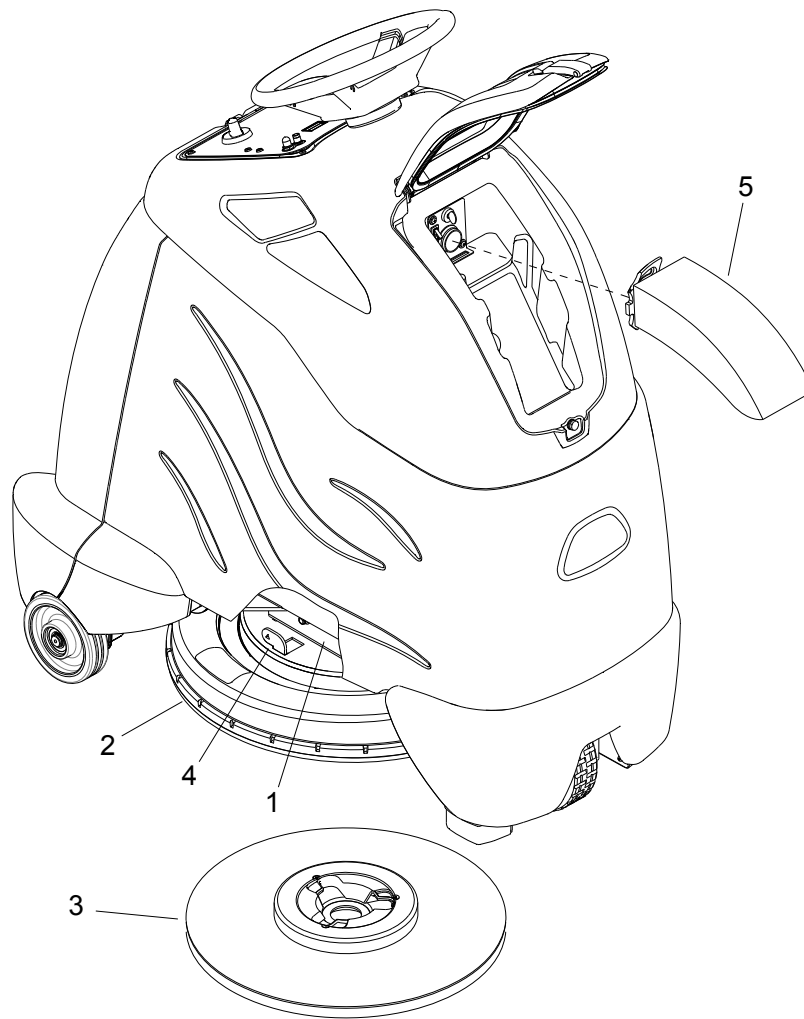

**Burnishing Deck**

- 1. Burnisher Motor
- 2. Skirt
- 3. Pad Driver/Pad
- 4. Pad Rotation Lock Lever

**Dust Collection**

- 5. Dust Bag

## Burnishing Pad

Many types of pads are available for floor burnishing. Select a pad type based on floor type and floor finish for best results.

## Dust Bag Replacement

1. Release latch and raise cover to access dust bag.
2. Turn thumb screw to horizontal position to release dust bag.
3. Remove dust bag at the plastic frame from the bag mounting bracket.
4. Reverse procedure to install new bag.

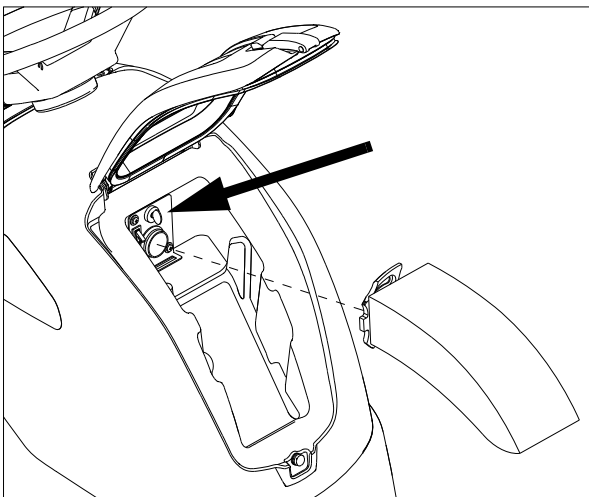

## Dust Control Skirt Replacement

1. Raise burnisher deck with Function Mode Switch set to transport mode.
2. Find ends of brush skirt. Pull down on one end to release from shroud snap features. Once released from two snaps, gently pull skirt parallel to the floor to fully remove from shroud.
3. Install new skirt by pushing up into snaps one at a time working around shroud diameter.
4. Where the ends meet, trim any excess skirt with scissors or wire cutter.

## Pad Replacement

1. Set the burnisher deck to the raised position.
2. To remove the pad driver:
  - Push in and hold the Pad Rotation Lock lever.
  - Grip the outside diameter of the pad and pad driver.

- Rotate firmly counterclockwise. Pad driver will disconnect from motor hub.
- Release Pad Rotation Lock lever.

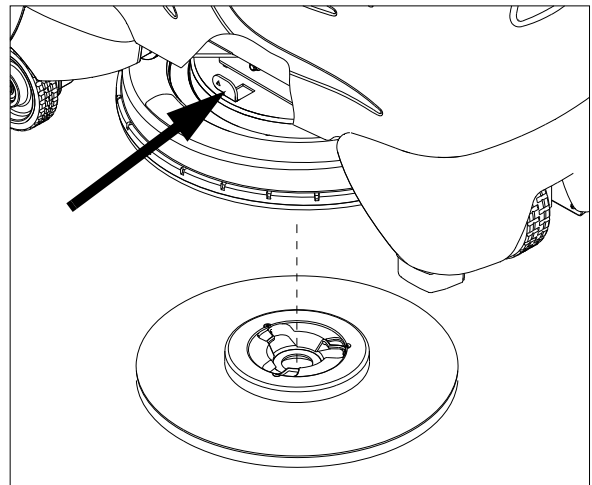

3. To remove pad from pad driver:
  - Set pad driver on flat surface with pad facing up.
  - Release pad retainer from center of pad using retainer's wire clip.
  - Peel pad off pad driver.
4. To install pad on pad driver:
  - Center the pad on pad driver with pad facing up.
  - Check the pad inner diameter where the pad fits over the raised ring of the pad retainer.
  - Install pad retainer making sure wire clips snap in place. Pad will need to compress to engage pad retainer clips
5. To install the pad driver:
  - Push in and hold the Pad Rotation Lock lever.
  - Hold the pad driver parallel to the floor under the shroud.
  - Lift pad driver up to contact hub keeping level and centered with motor shaft.
  - Rotate pad driver clockwise applying light pressure up on the hub. Pad driver will align with hub and move up.
  - Continue rotating clockwise approximately 15 degrees to fully engage hub.
  - Release Pad Rotation Lock lever.

*NOTE: Final tensioning of the pad driver occurs as the motor rotates during burnishing.*

### Burnisher Motor Replacement

1. Remove the pad driver assembly.
2. Lower the burnisher deck using the Function Mode Switch.
3. Turn the key to the off position.
4. Unplug the battery pack from the machine.
5. Disconnect the positive and negative wires from the posts at the front of the motor. Note the positions for reassembly. Isolate the ends of the wires as batteries will be connected in step 6.
6. Unhook deck lift springs, one per side. Prevent bracket from retracting inside body of machine by using holes and temporary cross pin.
7. Remove the hardware (4X) connecting the linkage to the motor mount. Note the stack arrangement of the hardware for reassembly.
8. Plug in the battery pack. Turn on the key. Turn the Function Mode Switch to transport to raise upper linkage.
9. Slide the deck assembly from under the machine.
10. Flip the deck assembly over.
11. Slide Pad Rotation Lock lever in and hold while removing bolt and washer from pad driver hub.
12. Release Pad Rotation Lock lever slide hub and key off motor shaft.
13. Remove bolts and washers (4X) holding inner shroud and plate. Remove motor from shrouds and motor mount.
14. Reverse process to reinstall.

### Burnisher Motor Carbon Brush Ring Replacement

1. Follow steps 1-9 of "Burnisher Motor Replacement" to access the top of the motor.
2. Remove flat head screws (4X) in the motor cover. Remove the cover.
3. Remove hex head screws (4X) holding the brush ring assembly to the motor casting.
4. Slide the brush ring assembly off the motor commutator.
5. Clean excessive carbon deposits off motor components with compressed air.

6. Prepare new brush assembly for use by inserting individual brush springs into brush guides. Check each brush to ensure proper movement after installing springs.
7. Depress brushes as required to insert brush housing over commutator.
8. Check area under cable lugs to make sure brush ring is seated against casting fully.
9. Replace hex head screws (4X) holding the brush ring assembly.
10. Rotate motor to check for smooth rotation.
11. Replace motor cover and flat head screws (4X).
12. Reverse steps in step 1 to reinstall to machine.

### Deck Actuator Removal / Replacement

**FOR SAFETY: Before leaving or servicing machine, stop on a level surface. Turn off machine.**

1. Support deck under pad driver so that actuator pins can be removed.
2. Remove bumper screws (2).
3. Remove front battery.
4. Pull steering shaft.
5. Disconnect actuator from wiring harness.
6. From the underside of the machine, remove lower lifting pin from actuator.
7. Remove clevis pin from actuator upper bracket.
8. Lift actuator upward and free from machine.
9. Reverse steps to install.

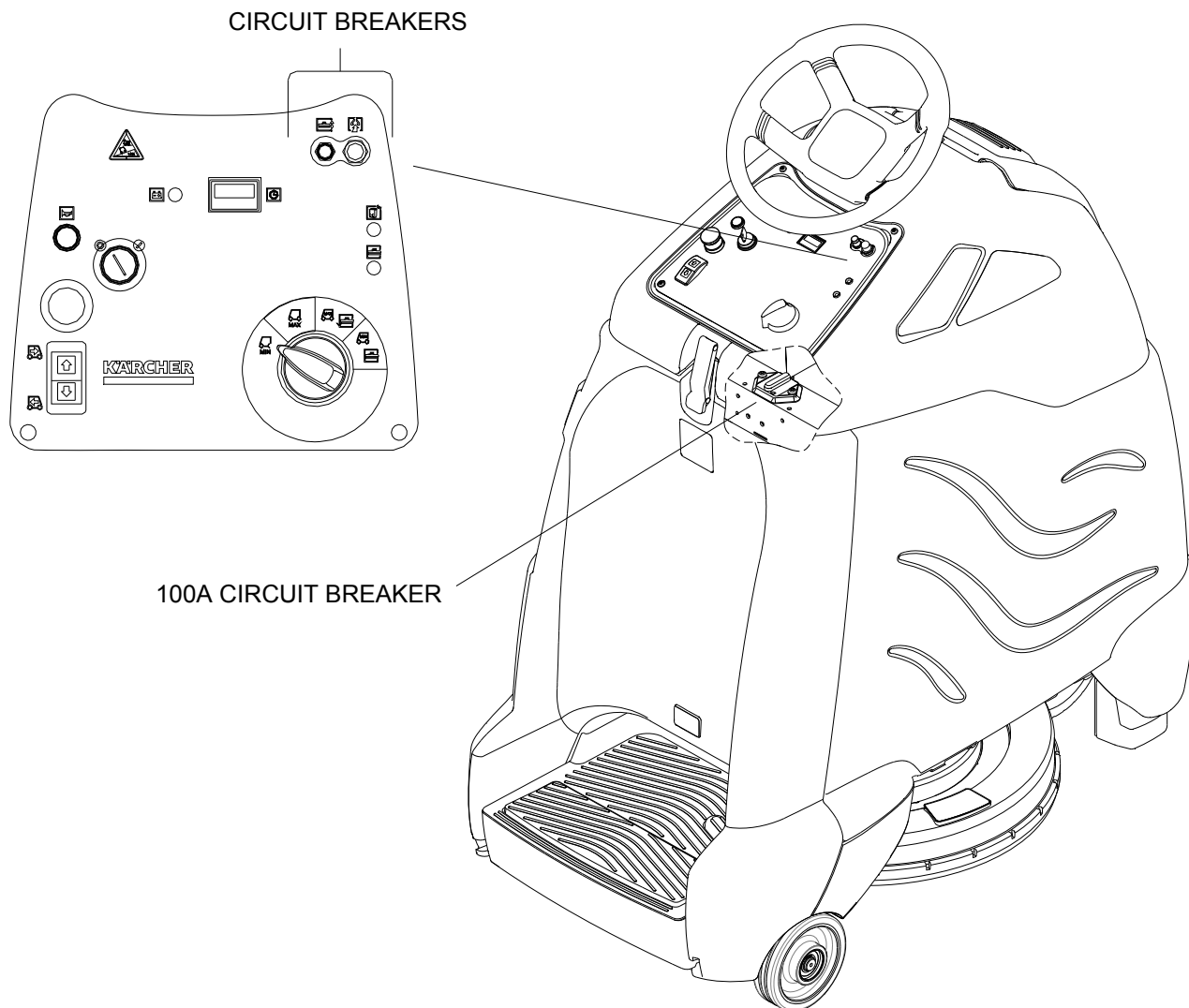

## Circuit Breakers

Circuit breakers interrupt the flow of power in the event of an electrical overload. When a circuit breaker is tripped, reset it by pressing the exposed button. If a circuit breaker continues to trip, the cause of the electrical overload should be found and corrected.



1.5 Amp protects the deck lift actuator, horn & controller.



18 Amp protects the vacuum motor.

100 Amp protects the burnisher motor.

### **Body Assembly Removal**

In order to access the frame or drive components, the entire tank/console cover assembly can be removed as a single unit.

Body Removal:

1. Open the console cover.
2. Remove back panel.
3. Grasp the lower end of the flexible steering shaft and pull it straight up until it is disengaged with the hex steering shaft.
4. Disconnect the five electrical plugs located just forward of the battery tray. Access plugs through front left hole in main body.
5. Remove the battery cable connection from the rear cross member.
6. Close the console cover.
7. Remove the bumper. One mounting bolt per side is located just above the tip pads on the inside.
8. Remove 6 bolts holding the body in place.
9. The body assembly can now be lifted off the chassis and set aside.
10. Reverse the process for reassembly.

### **Drive Unit Removal**

1. Remove tank assembly.
2. Pull the brake and drive electrical connectors off of their support plate.
3. Remove the P-clamp holding the cable.
4. Lift the chain cover plate off of the motor.
5. Support the chassis on the tip pads so that the front wheel is 10 inches off the floor.
6. Locate and remove two mounting nuts and remove the drive unit from below.
7. To reinstall, reverse the process.

*NOTE: The small tab at the front of the drive unit frame should line-up with the notch in the mating plate.*



## **Maintenance**

### **Vacuum - Optional**

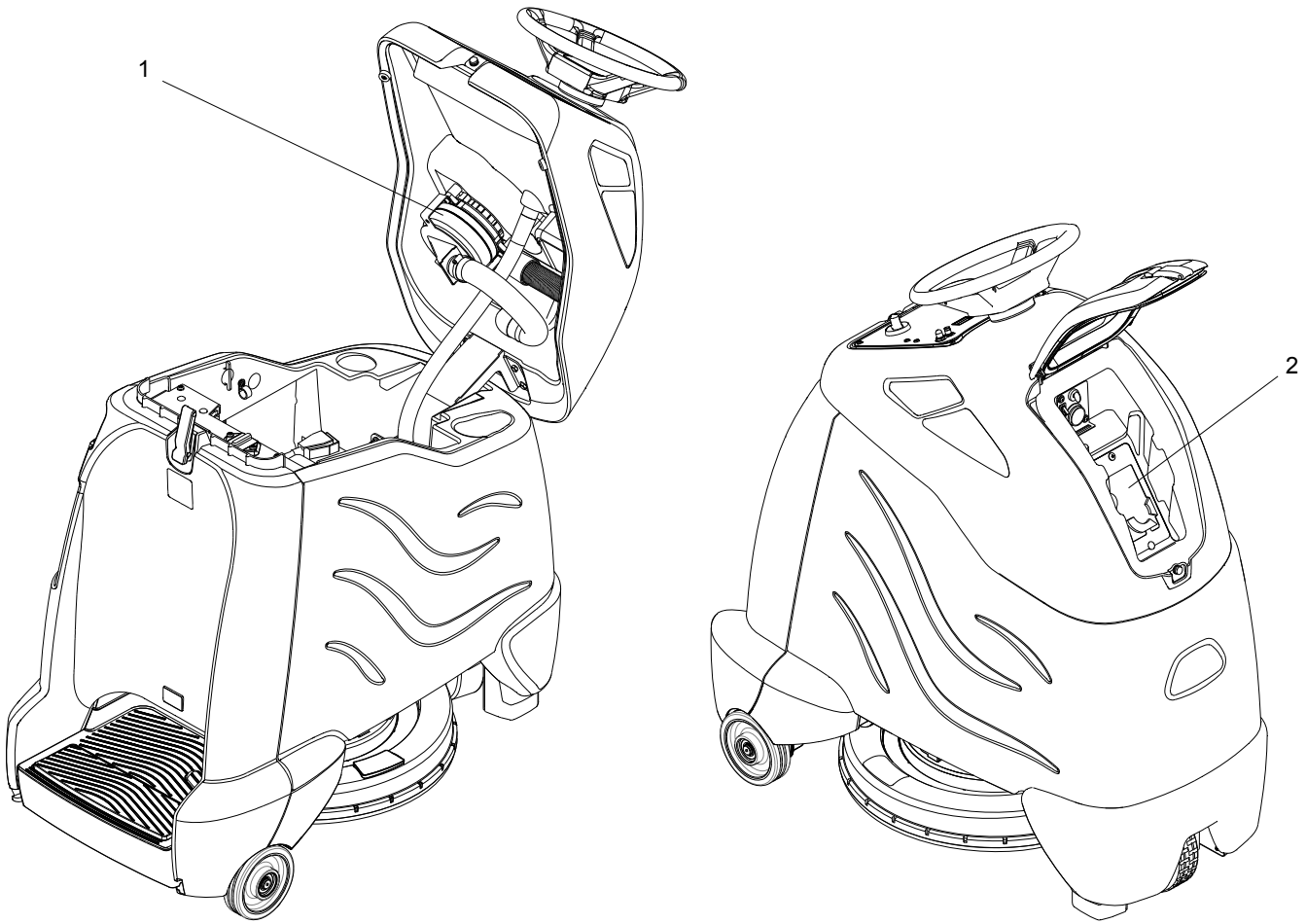

1. Vacuum Motor

2. Vacuum Filter



### To Replace Vacuum Filter

1. Open dust bag cover.
2. Remove dust bag.
3. Unlock bottom of filter frame by bending it slightly and slide from under the bolt head.
4. Lift filter out of housing.
5. Reverse steps to install.

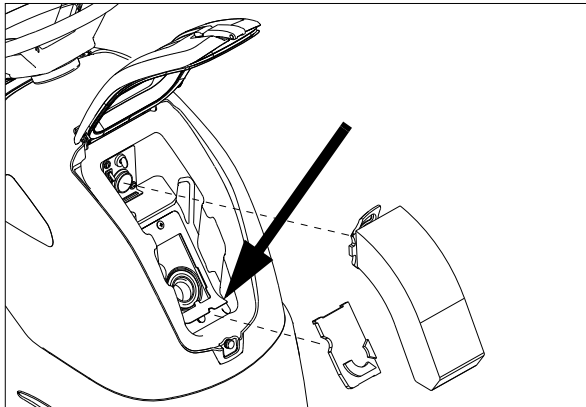

### Vacuum Motor Carbon Brush Replacement

**FOR SAFETY:** before leaving or servicing machine, stop on a level surface, turn off machine and disconnect power.

Vacuum Motor Carbon Brushes

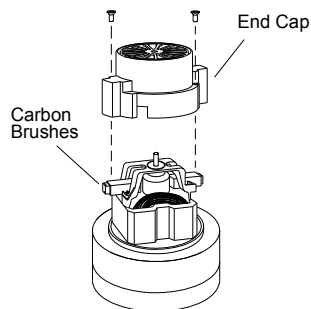

If armature commutator is grooved, extremely pitted or not concentric, the motor will need to be replaced or sent to a qualified service center.

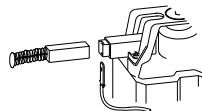

**Important:**

These brushes wear quicker as the length shortens due to increased heat. Spring inside brush housing will damage motor if brushes are allowed to wear away completely.

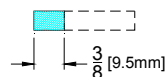

Periodically check the length of the carbon brushes. Replace both carbon brushes when either is less than 3/8" (9.5mm) long.

### To Repair or Replace Vacuum Motor

1. Remove four (4) screws from top of control panel.
2. Tip control panel back from console to expose vacuum motor wires.
3. Disconnect electrical connector from the vacuum motor.
4. Replace control panel, attach with one (1) screw to secure in place.
5. Open console.
6. Remove three (3) screws and mounting bracket that secure vacuum motor.
7. Reverse steps to install.

**MOUNT .80" FROM SEALING SURFACE OF CONSOLE TO THE TOP OF THE MOUNTING TABS (3).**

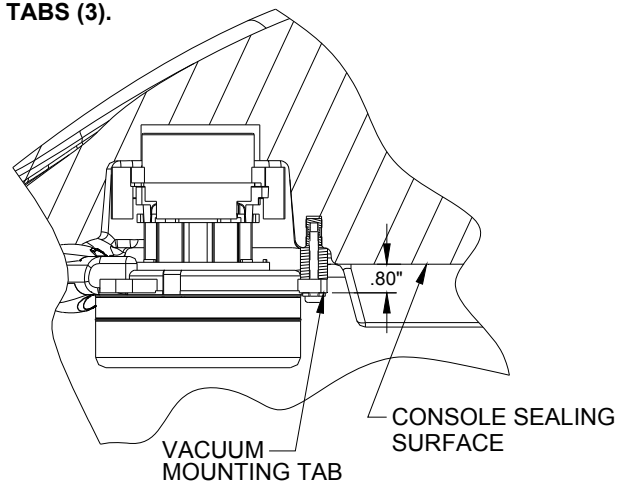

**NOTE:** If vacuum motor is not mounted as shown, vacuum may not seal properly, resulting in poor performance.

### Drive Motor-From Serial Number (3\*)

#### Drive Motor Carbon Brush Replacement

##### **⚠ CAUTION:**

Do not use a pressure washer to clean around the brush motors. Use tap pressure only.

##### **⚠ ATTENTION:**

**N'utilisez pas de nettoyeur haute pression pour nettoyer autour des moteurs des brosses. Utilisez seulement la pression du robinet.**

*FOR SAFETY: Before leaving or servicing machine, stop on a level surface, turn off machine and remove motor carbon brushes.*

1. Open the console cover.
2. Tilt the rear panel back until it stops on the lanyard.
3. Grasp the lower end of the flexible steering shaft and pull it straight up until it is disengaged with the hex steering shaft.
4. Remove the cover and gasket at the steering shaft area.
5. Grasp the drive wheel by reaching under the front bumper and turn it to near the left steering stop.
6. The drive motor carbon brushes are located under the metal band. Remove the band to access the 4 brushes.
7. Remove the phillips screw that holds each lead. Remove the brushes.
8. Install the new brushes and reinstall the band.
9. Replace the gasket and cover, set the drive wheel straight ahead, set the steering wheel straight ahead, and gently align the steering shaft coupling and slide onto the lower shaft.
10. Slowly close the cover and make sure the shaft slides without binding.

### Drive Chain Tension

The drive chain should deflect about 1/4 inch on either side of the loop when the opposite side is tight.

To adjust chain tension:

1. Remove bumper.
2. Loosen the 1/4" nut behind the idler sprocket.
3. Tighten the front screw to increase chain tension.
4. Re-tighten the 1/4" nut behind the idler.
5. Reinstall the bumper.

### Transporting Machine

This machine is equipped with a drive gear engagement/disengagement lever.

The brake automatically engages and keeps the machine from moving whenever the operator stops the machine.

The drive gear can be disengaged so the machine can be pushed or towed (slowly).

When the drive gear is disengaged the machine cannot be driven.

## Brake Override

1. Disconnect battery to prevent injury.
2. Turn wheel slightly to the right.
3. Access to the Brake lever is through the access port on the front left side of the Lower Body.

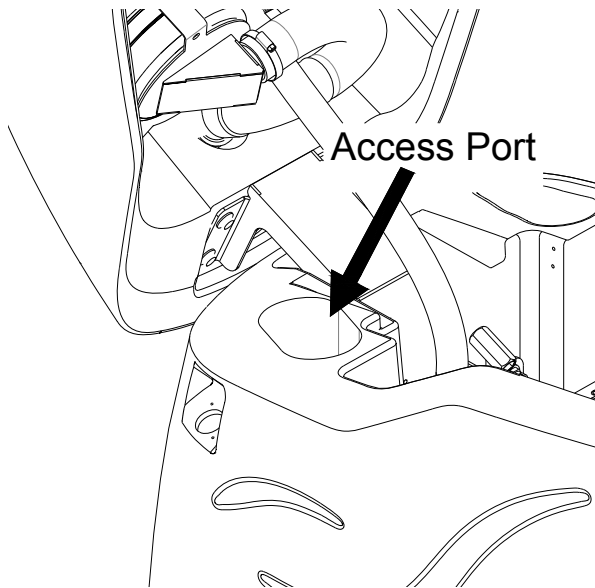

4. Push the lever as indicated to disengage the brake.

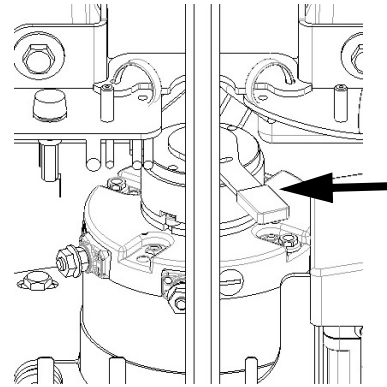

5. Push the machine slowly. Take care as voltage is generated while pushing the machine and may cause the controller to temporarily stop the machine.

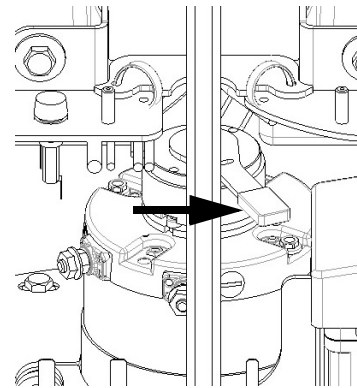

6. To re-engage the brake, push the lever as indicated.

## Inclines

When navigating an incline the machine may come to a stop. Turn the machine off. Wait 5 minutes and start the machine and proceed up the incline.

### **⚠ CAUTION:**

Overheating may occur if you do not wait the full 5 minutes.

### **⚠ ATTENTION:**

Une surchauffe peut se produire si vous n'attendez pas les 5 minutes complètes.

### Drive Motor-Prior to Serial Number (3\*)

#### Drive Motor Carbon Brush Replacement

##### **⚠ CAUTION:**

Do not use a pressure washer to clean around the brush motors. Use tap pressure only.

##### **⚠ ATTENTION:**

**N'utilisez pas de nettoyeur haute pression pour nettoyer autour des moteurs des brosses. Utilisez seulement la pression du robinet.**

*FOR SAFETY: Before leaving or servicing machine, stop on a level surface, turn off machine and remove motor carbon brushes.*

1. Open the console cover.
2. Tilt the rear panel back until it stops on the lanyard.
3. Grasp the lower end of the flexible steering shaft and pull it straight up until it is disengaged with the hex steering shaft.
4. Remove the cover and gasket at the steering shaft area.
5. Grasp the drive wheel by reaching under the front bumper and turn it to near the left steering stop.
6. The drive motor carbon brushes are located under screw caps. The caps are accessible by gently moving the harness aside.
7. Rotate the drive wheel to near the right hand stop to access the right side carbon brush.
8. Replace the gasket and cover, set the drive wheel straight ahead, set the steering wheel straight ahead, and gently align the steering shaft coupling and slide onto the lower shaft.
9. Slowly close the cover and make sure the shaft slides without binding.

### Drive Chain Tension

The drive chain should deflect about 1/4 inch on either side of the loop when the opposite side is tight.

To adjust chain tension:

1. Remove bumper.
2. Loosen five (5) screws that hold the drive gear motor and slide the gear motor up until the chain tension is correct. Tighten the five (5) mounting screws.
3. Models equipped with jack screw on front side of drive should not use jack screw to apply tension. Use only as a stop once chain is properly tensioned.
4. Reinstall the bumper.

### Transporting Machine

This machine is equipped with a drive gear engagement/disengagement lever.

The brake automatically engages and keeps the machine from moving whenever the operator stops the machine.

The drive gear can be disengaged so the machine can be pushed or towed (slowly).

When the drive gear is disengaged the machine cannot be driven.

NOTE: Front bumper removed for clarity and to show access to lever.

## Lever access

Turn wheel to left and reach up under bumper and steel brake.

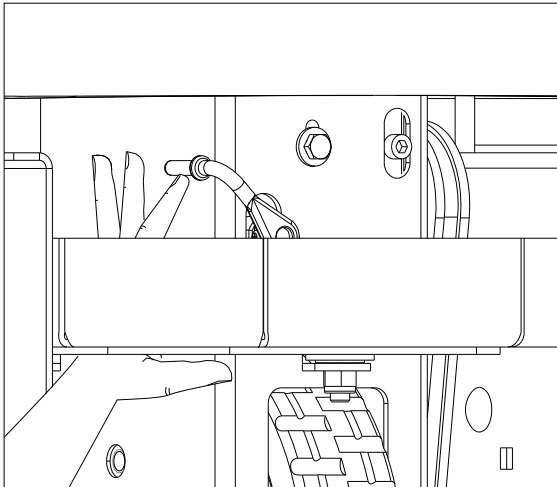

## Drive gear engaged

Machine can be driven.

Rotate lever firmly in direction of arrow

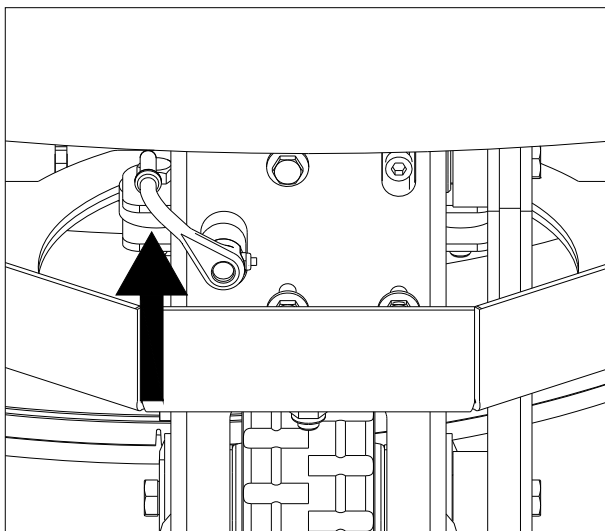

## Drive gear disengaged

Machine can be pushed or towed (slowly).

When disengaged the machine rolls easily. Disengage on a level surface.

Rotate lever firmly in direction of arrow.

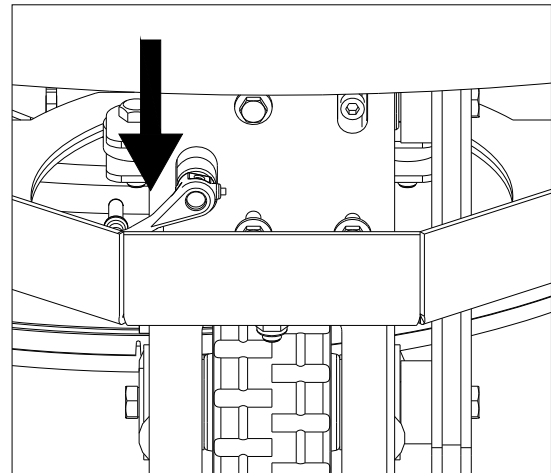

## Inclines

When navigating an incline the machine may come to a stop. Turn the machine off. Wait 5 minutes and start the machine and proceed up the incline.

### **⚠ CAUTION:**

Overheating may occur if you do not wait the full 5 minutes.

### **⚠ ATTENTION:**

Une surchauffe peut se produire si vous n'attendez pas les 5 minutes complètes.

## **Maintenance**

### **Preparation for Loading/Unloading Trailer**

Burnisher Deck must be in the up position before loading.

When transporting the machine on a trailer or in a truck, in addition to using tie-downs, be sure to block the tires to prevent the machine from rolling.

### **Machine Tie-Downs**

There are two tie points located in front of the rear wheels on the frame, and a Tie-down wrap point on the back panel. Tie-down devices must be of the proper type and strength. The combined strength of all tie-downs must be strong enough to lift two times the weight of the machine. Tie-downs must be positioned to prevent the machine from moving forward, backward, or either side to side. Use all four corners of the machine with the tie-downs running out opposite directions. Tie-downs must be attached to the transporting vehicle securely.

### **Recommended Tie-Down Points**

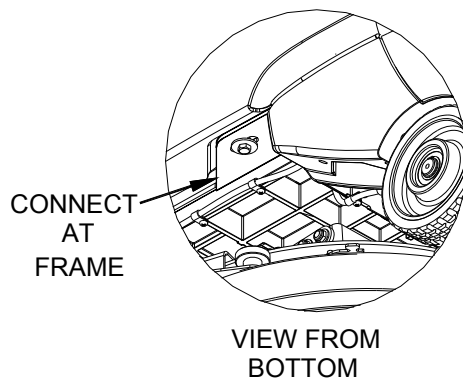
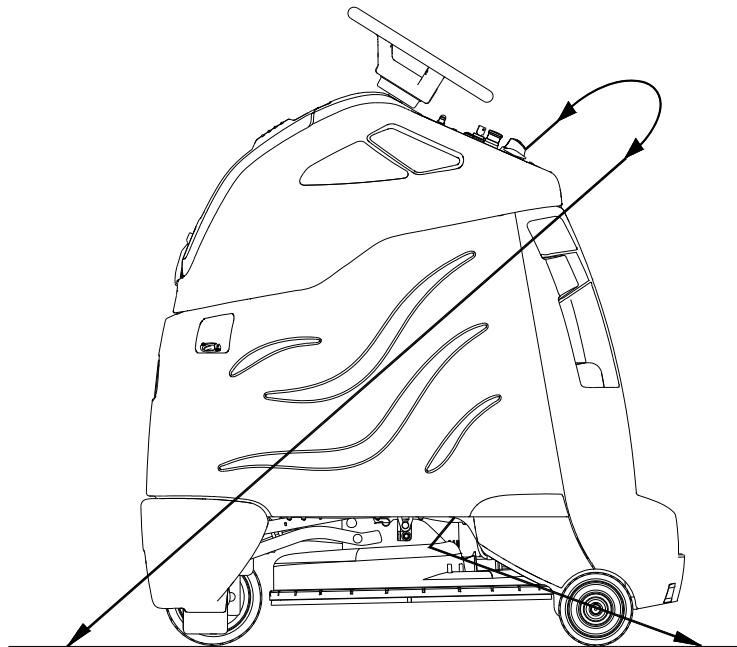

**Troubleshooting**

<b>PROBLEM</b>	<b>CAUSE</b>	<b>SOLUTION</b>
No machine function	Console lid is open	Close console lid
No power to machine	Battery disconnected	Check all battery cable connections
	Emergency shut-off activated	Reset
	Battery cables corroded	Clean connections
	Faulty key switch	Replace switch
	Batteries not plugged in	Plug batteries in
	On Board charger plugged in	Un-plug and stow cord
Little or no propel	Low battery charge	Charge batteries
	Tripped circuit breaker	Reset controller circuit breaker
	Controller protecting motor from overload	Controller limits motor amperage. Allow unit to cool down for several minutes.
	Machine is stalled against an obstacle (threshold, curb, etc.)	Remove obstacle or push machine away from obstacle
	Controller overheated	Allow cool down period
	Loose motor connection	Check wires and connections from controller to motor
	Faulty throttle circuit or potentiometer	Check wires and connections from and potentiometer resistance
	Drive Lever disengaged	Engage drive
Machine does not change speeds	Faulty speed control circuit or switch	Check wires & connections
Forward speed only	Faulty forward/reverse circuit	Check wires & connections
Reverse speed only		
Battery indicator light flashing	Battery needs charged	Charge Battery
	Controller is indicating a fault code	See fault code table

## Maintenance

PROBLEM	CAUSE	SOLUTION
Vacuum motor does not run, or runs slowly	Faulty vacuum circuit or switch	Check wires & connections
	Worn vacuum motor brushes	Replace brushes, check commutator
	Vacuum circuit breaker tripped	Reset circuit breaker
Poor burnishing performance	Debris caught in pad	Remove debris or change pad
	Worn pad	Replace pad or flip pad
	Improper pad used	Contact equipment or application specialists
	Low battery charge	Charge batteries
Burnisher motor does not run, or runs slowly	Circuit breaker tripped	Reset circuit breaker
	Low battery charge	Charge battery
	Faulty brush circuit or motor	Check wires, connections and motor
	Worn brush motor brushes	Replace brushes, check commutator
Deck does not go down	Actuator circuit breaker tripped	Reset actuator circuit breaker



## Battery Discharge Indicator Troubleshooting

The battery indicator flashes when a problem occurs. The table below list solutions for the indicated problems.

Number of flashes	Problem	Solution
1	The battery needs charging, there is a bad connection to the battery or dependent on the programming, may indicate that the battery lockout function is active and the controller is in a restricted mode of operation. Check the connections to the battery.	If the connections are good, try charging the battery.
2	There is a bad connection to the drive motor.	Check all connections between the motor and the controller.
3	The drive motor has a short circuit to a battery connection.	Contact your service agent.
4	The battery charge level has fallen below the battery Lockout Level and the controller is inhibiting burnisher motor function.	Charge the battery.
5	Not used.	-
6	The controller is being inhibited from driving, this may be because the battery charger is connected (on board charger only).	Disconnect battery charger.
7	A throttle fault is indicated.	Make sure that the throttle is in the rest position before switching on the machine.
8	A controller fault is indicated.	Make sure that all connections are secure.
9	The parking brake has a bad connection.	Check the parking brake and motor connections. Make sure the controller connections are secure.
10	An excessive voltage has been applied to the controller. This is usually caused by a poor battery connection.	Check the battery connections.
-	Blinks once every 5 seconds	Sleep mode, cycle key switch

## Suggested Spare Parts

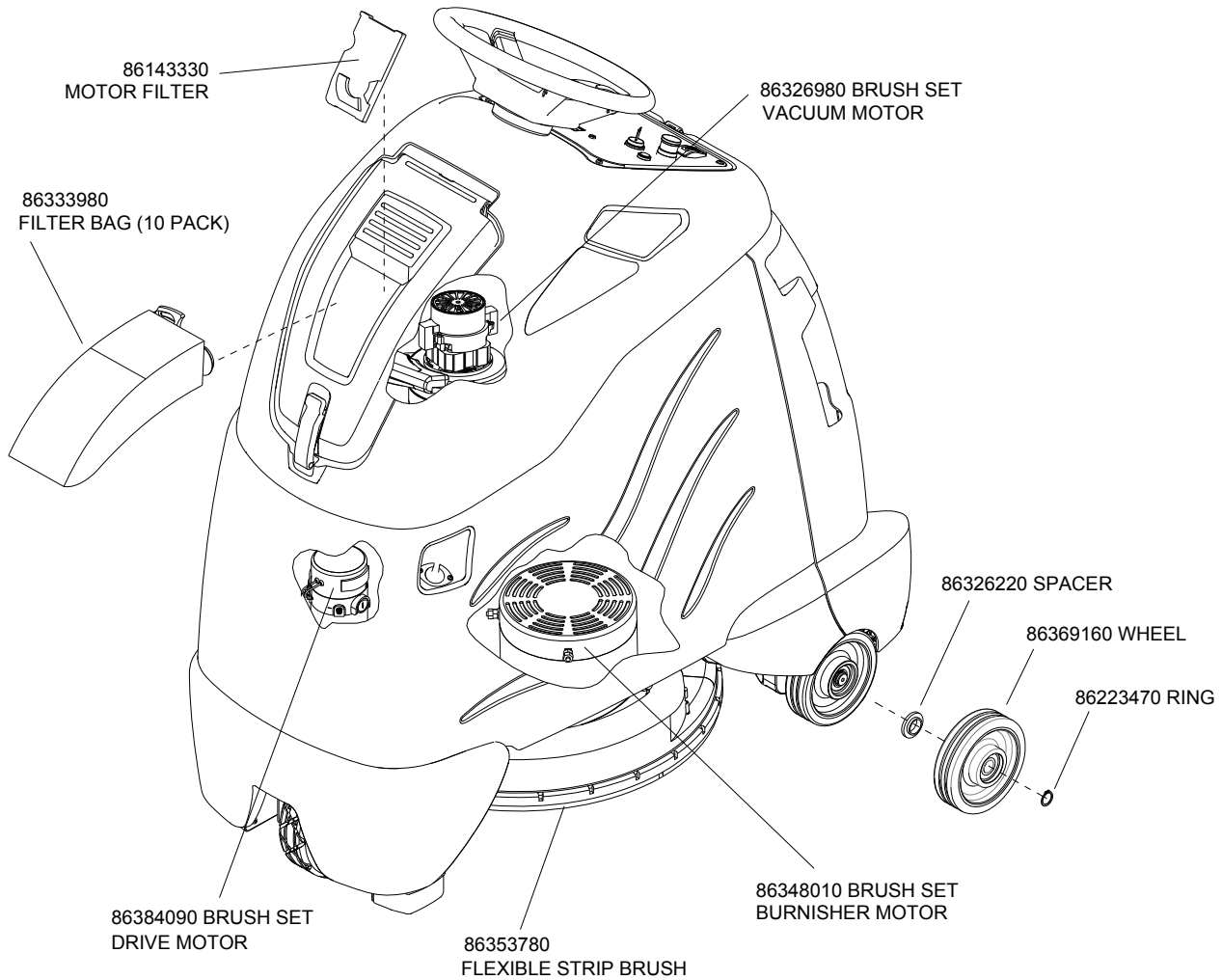

# KÄRCHER

makes a difference

## Spare Parts List

### Chariot 2 iGloss 20

<b>1.002-031.0</b>	<b><i>CBPS20</i></b>
<b>1.002-032.0</b>	<b><i>CBPSC20</i></b>
<b>1.002-033.0</b>	<b><i>CBPL20</i></b>
<b>1.002-034.0</b>	<b><i>CBPLC20</i></b>
<b>1.002-035.0</b>	<b><i>CBAL20</i></b>
<b>1.002-036.0</b>	<b><i>CBALC20</i></b>

From Serial Number (Ref No. 1\*)  
\* See Serial Number page  
or call manufacturer.

## Table of contents

---

CHARIOT iGLOSS 20", SB, PASS, SHLF CHRGR (1.002-031.0)	2
40 BODY BRACE (0.250-162.0)	3
50 BODY LOWER (0.250-035.0)	5
60 BODY LOWER MOUNTING (0.250-034.0)	7
70 BUMPER (0.250-375.0)	9
80 BURNISHING DECK (0.250-377.0)	11
90 BURNISHING DECK MOUNTING (0.250-378.0)	13
100 BURNISHING DECK LIFT (0.250-379.0)	15
110 BURNISHING DECK - PAD DRIVER (0.250-392.0)	17
120 CONSOLE - BAG ENCLOSURE (0.250-393.0)	19
130 CONSOLE - HINGE (0.250-394.0)	21
140 CONTROL PANEL 1 (0.250-395.0)	23
150 CONTROL PANEL 2 (0.250-402.0)	25
160 CHARGER - OPTIONAL (0.250-403.0)	27
170 DECALS (0.250-404.0)	29
180 SLEW/STEERING-FROM SERIAL NUMBER (3*) (0.250-405.0)	31
190 DRIVE-CHAIN PRIOR TO SERIAL NUMBER (3*) (0.250-406.0)	33
200 DRIVE LOWER - FROM SERIAL NUMBER (3*) (0.250-411.0)	35
1 Traction motor C2 (8.641-117.0)	38
210 DRIVE-LOWER PRIOR TO SERIAL NUMBER (3*) (0.250-412.0)	40
5 Wheel drive motor (8.636-401.0)	43
220 FRAME & REAR WHEELS (0.250-417.0)	45
230 DRIVE MOUNTING - FROM SERIAL NUMBER (3*) (0.250-418.0)	47
240 DRIVE MOUNTING - PRIOR TO SN (3*) (0.250-419.0)	49
250 PEDAL PLATFORM (0.250-420.0)	51
260 PEDAL PLATFORM MOUNTING (0.250-421.0)	53
270 STEERING (0.250-461.0)	55
280 VACUUM - OPTIONAL (0.250-462.0)	57
290 WIRING - BATTERY (0.250-463.0)	58
9020 Chariot iGloss 20 Serial Numbers (0.250-921.0)	60

CHARIOT iGLOSS 20", SB, PASS, SHLF CHRGR (1.002-031.0)

POS	Article no.	Description	Quantity	Unit
40	0.250-162.0	BODY BRACE	1.000	ST
50	0.250-035.0	BODY LOWER	1.000	ST
60	0.250-034.0	BODY LOWER MOUNTING	1.000	ST
70	0.250-375.0	BUMPER	1.000	ST
80	0.250-377.0	BURNISHING DECK	1.000	ST
90	0.250-378.0	BURNISHING DECK MOUNTING	1.000	ST
100	0.250-379.0	BURNISHING DECK LIFT	1.000	ST
110	0.250-392.0	BURNISHING DECK - PAD DRIVER	1.000	ST
120	0.250-393.0	CONSOLE - BAG ENCLOSURE	1.000	ST
130	0.250-394.0	CONSOLE - HINGE	1.000	ST
140	0.250-395.0	CONTROL PANEL 1	1.000	ST
150	0.250-402.0	CONTROL PANEL 2	1.000	ST
160	0.250-403.0	CHARGER - OPTIONAL	1.000	ST
170	0.250-404.0	DECALS	1.000	ST
180	0.250-405.0	SLEW/STEERING-FROM SERIAL NUMBER (3*)	1.000	ST
190	0.250-406.0	DRIVE-CHAIN PRIOR TO SERIAL NUMBER (3*)	1.000	ST
200	0.250-411.0	DRIVE LOWER - FROM SERIAL NUMBER (3*)	1.000	ST
210	0.250-412.0	DRIVE-LOWER PRIOR TO SERIAL NUMBER (3*)	1.000	ST
220	0.250-417.0	FRAME & REAR WHEELS	1.000	ST
230	0.250-418.0	DRIVE MOUNTING - FROM SERIAL NUMBER (3*)	1.000	ST
240	0.250-419.0	DRIVE MOUNTING - PRIOR TO SN (3*)	1.000	ST
250	0.250-420.0	PEDAL PLATFORM	1.000	ST
260	0.250-421.0	PEDAL PLATFORM MOUNTING	1.000	ST
270	0.250-461.0	STEERING	1.000	ST
280	0.250-462.0	VACUUM - OPTIONAL	1.000	ST
290	0.250-463.0	WIRING - BATTERY	1.000	ST
9020	0.250-921.0	Chariot iGloss 20 Serial Numbers	1.000	ST

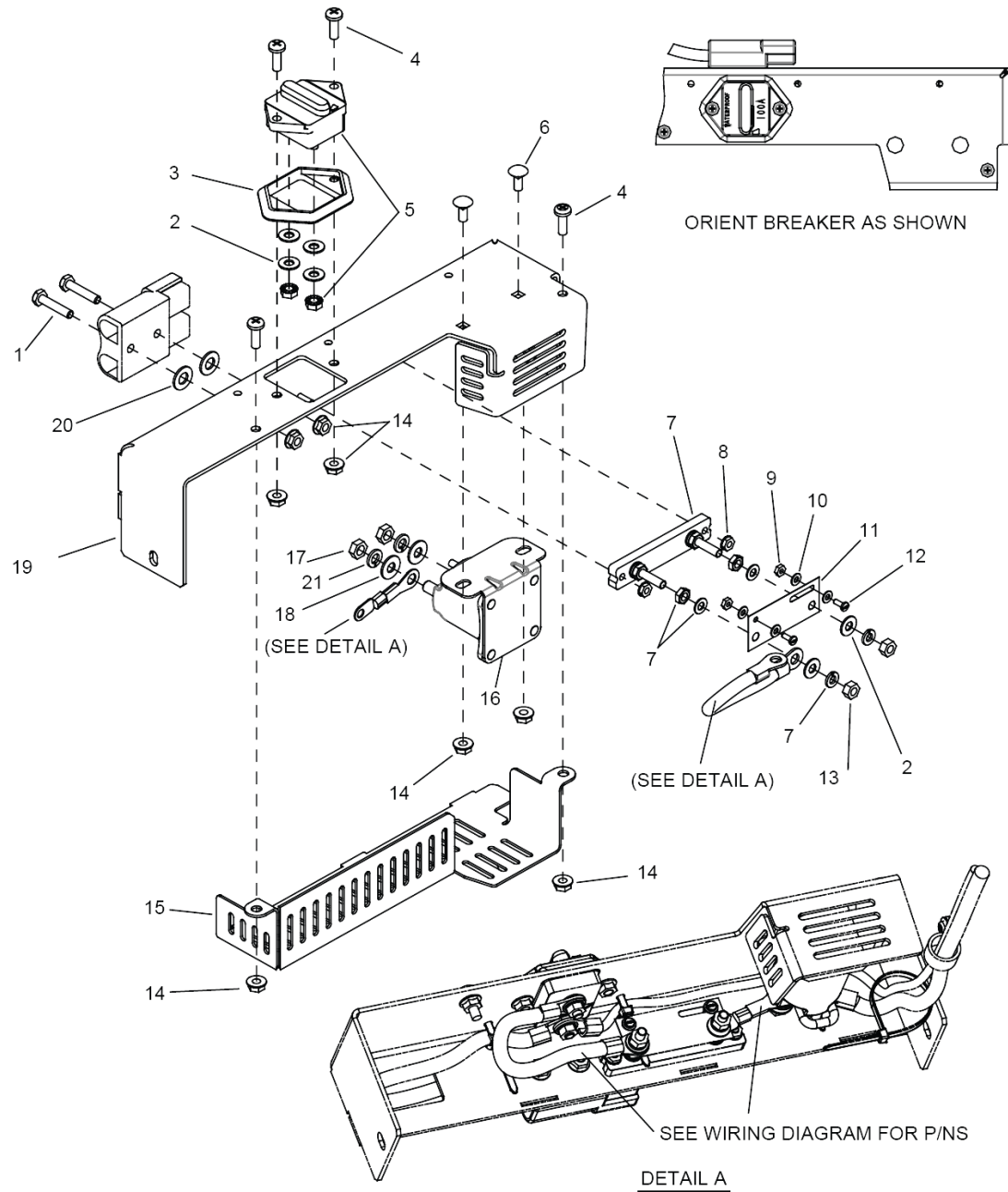

## 40 BODY BRACE (0.250-162.0)

POS	Article no.	Description	Quantity	Unit
1	8.627-382.0	SCREW, 1/4-20 X 1.25 HHMS SS	2.000	ST
2	8.601-063.0	WASHER, 1/4 SS	6.000	ST
3	8.634-002.0	COVER, PANEL MNT BREAKER	1.000	ST
4	8.627-512.0	SCREW, 1/4-20 X .75 PHPNHMS STL ZNPLT	4.000	ST
5	8.634-003.0	BREAKER, 100A CIRCUIT	1.000	ST
6	8.627-750.0	SCREW, 1/4-20 X .625 CARR SS	2.000	ST
7	8.622-977.0	BLOCK, SHUNT MOUNT	1.000	ST
8	8.600-570.0	NUT, 10-32 HEXSTRW LK STL ZNPLT	2.000	ST
9	8.627-179.0	NUT, 6-32 HEX BRS	2.000	ST
10	8.627-960.0	WASHER, 6 FLT BRS	4.000	ST
11	8.625-360.0	SHUNT, 50MV 70AMP	1.000	ST
12	8.627-625.0	SCREW, 6-32 X .375 SLTDPNHMS BRS	2.000	ST
13	8.627-077.0	NUT, 1/4-20 HEX SS	2.000	ST
14	8.627-137.0	NUT, 1/4-20 SERFLG STL ZNPLT	8.000	ST
15	8.635-327.0	BRACKET, CONTACTOR COVER	1.000	ST
16	8.637-145.0	RELAY 36VDC 100A HD	1.000	ST
17	8.627-112.0	NUT, 5/16-18 HEX BRS	2.000	ST
18	8.601-067.0	WASHER, 5/16 FLT SS	2.000	ST
19	8.635-326.0	BRACKET, SOL TANK BRACE	1.000	ST
20	8.601-068.0	WASHER, 3/8 NYL	2.000	ST
21	8.627-913.0	WASHER, 5/16 SPLT STL ZNPLT	2.000	ST

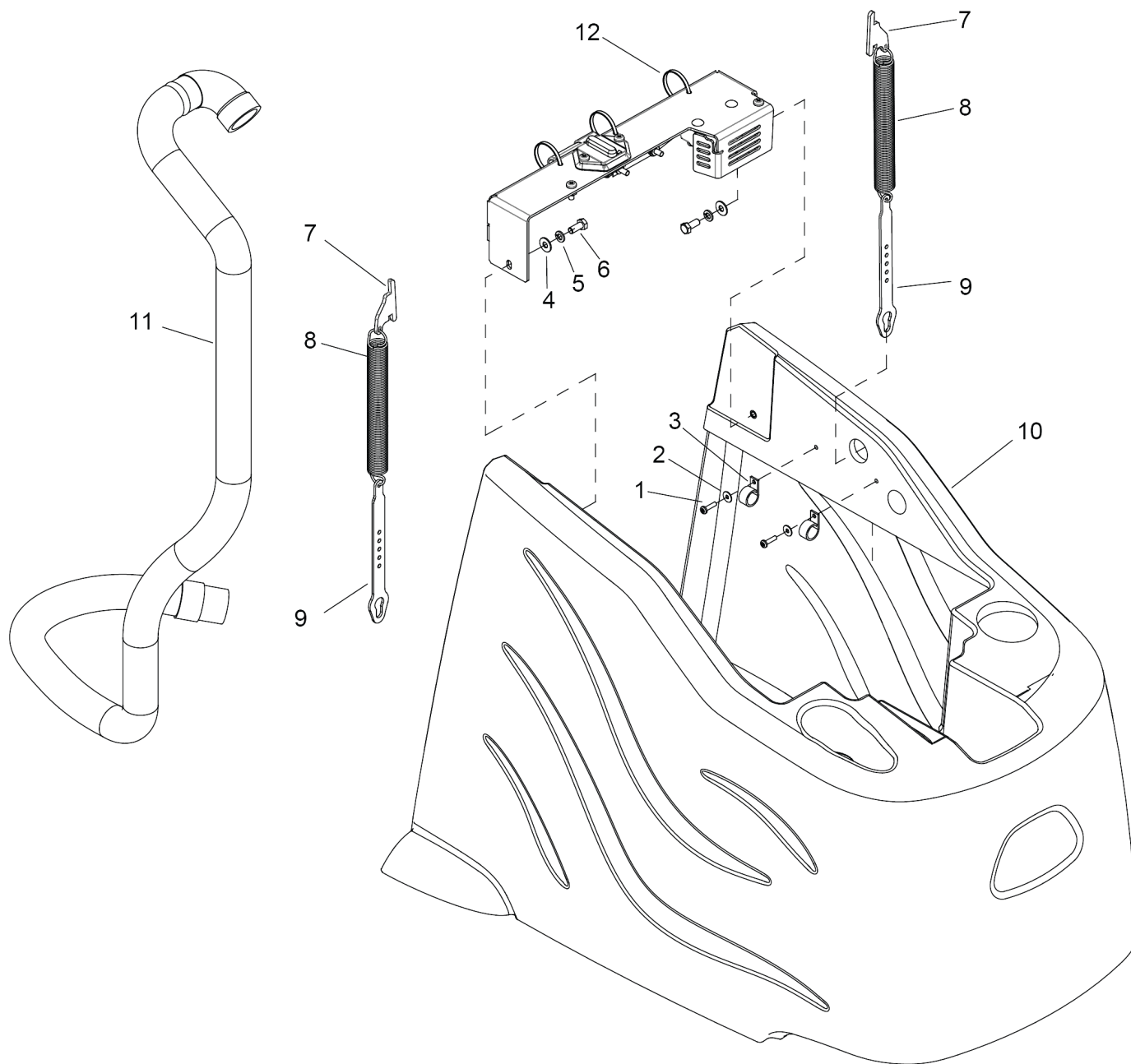



50 BODY LOWER (0.250-035.0)

POS	Article no.	Description	Quantity	Unit
1	8.627-398.0	SCREW, 10-32 X .75 PHPNHMS SS	2.000	ST
2	8.601-065.0	WASHER, .203 X .562 X .040 FLT	2.000	ST
3	8.635-499.0	CLAMP, .75 DIA, FLEX LOOP, NYLON	2.000	ST
4	8.601-067.0	WASHER, 5/16 FLT SS	2.000	ST
5	8.627-913.0	WASHER, 5/16 SPLT STL ZNPLT	4.000	ST
6	8.627-678.0	SCREW, 5/16-18 X .75 HHCS SS	2.000	ST
7	8.635-457.0	BRACKET, SPRING, UPPER	2.000	ST
8	8.635-322.0	SPRING, EXTENSION	2.000	ST
9	8.635-372.0	BRACKET, SPRING, LOWER	2.000	ST
10	8.637-770.0	MAIN BODY, NO OBC, GRAY, TRIM	1.000	ST
	<b>Item text1:</b> SHELF CHARGER MODELS ONLY,			
	<b>Item text2:</b> 1.002-033.0 AND 1.002-035.0			
10	8.636-841.0	Main body	1.000	ST
11	8.635-328.0	Hose	1.000	ST
12	8.626-494.0	Cable tie 11.38" UL/CSA	3.000	ST

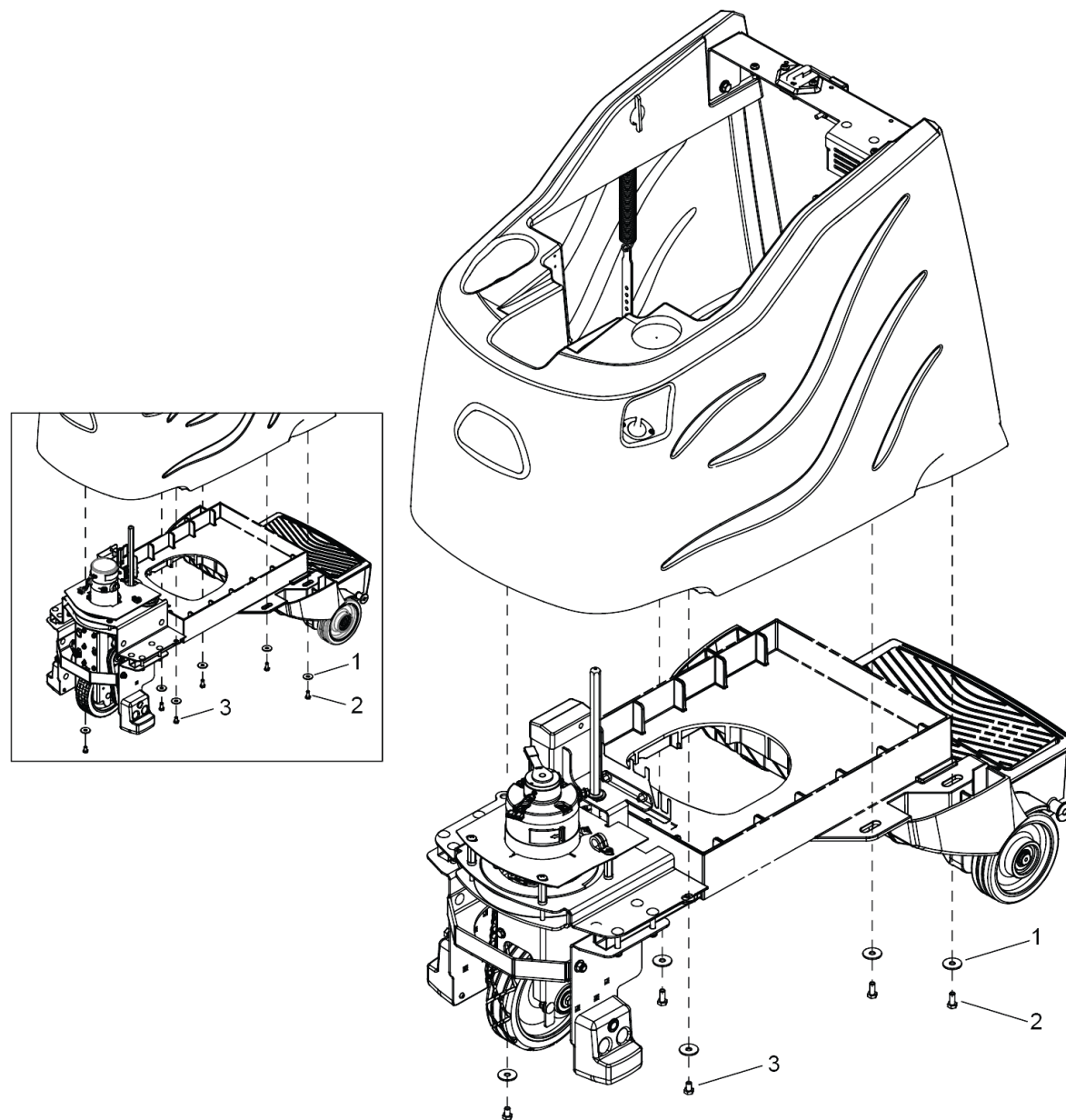

SEE SERIAL NUMBER PAGE FOR REFERENCE

60 BODY LOWER MOUNTING (0.250-034.0)

POS	Article no.	Description	Quantity	Unit	Serial number from
1	8.627-963.0	WASHER, 5/16 X 1.13 X .09 FLT	5.000	ST	*(3)
	<b>Item text1:</b> QTY WAS 6				
2	8.600-676.0	SCREW, 5/16-18 X .75 HHCS	3.000	ST	*(3)
	<b>Item text1:</b> QTY WAS 4				
3	8.627-518.0	SCREW, 5/16-18 X .5 STL GR5 ZNPLT	2.000	ST	

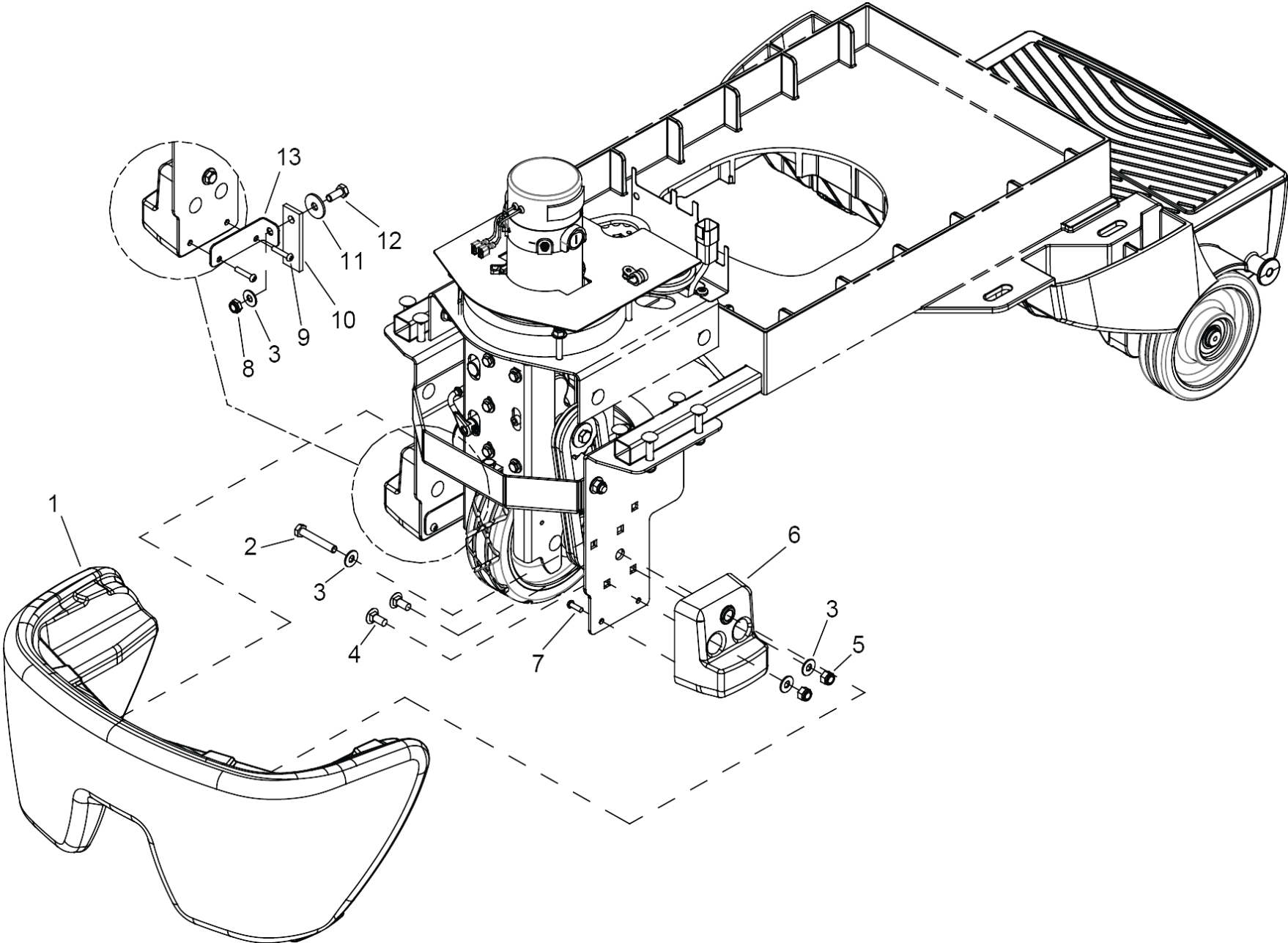

## 70 BUMPER (0.250-375.0)

POS	Article no.	Description	Quantity	Unit
1	8.636-682.0	BUMPER, TRIM, BLACK	1.000	ST
2	8.627-698.0	SCREW, 5/16-18 X 2 HHCS SS	2.000	ST
3	8.601-067.0	WASHER, 5/16 FLT SS	7.000	ST
4	8.627-607.0	SCREW, 5/16-18 X .75 CARR SS	4.000	ST
5	8.627-083.0	NUT, 5/16-18 HEX NYLOCK SS	4.000	ST
6	8.632-395.0	PAD TIP	2.000	ST
7	7.303-104.0	Screw 5x16 -A2-70 (IN6RD)	2.000	ST
8	8.627-184.0	NUT, 5/16-18 HEXTHIN NYLOCK SS	1.000	ST
9	8.632-791.0	SCREW, KA50 X 25 PTOVHS STL WN1412 ZNPLT	2.000	ST
10	8.625-613.0	STRAP, STATIC, .2T X 1W X 3L	1.000	ST
11	8.627-963.0	WASHER, 5/16 X 1.13 X .09 FLT	1.000	ST
12	8.600-676.0	SCREW, 5/16-18 X .75 HHCS	1.000	ST
13	8.635-951.0	BRKT, STATIC STRAP	1.000	ST

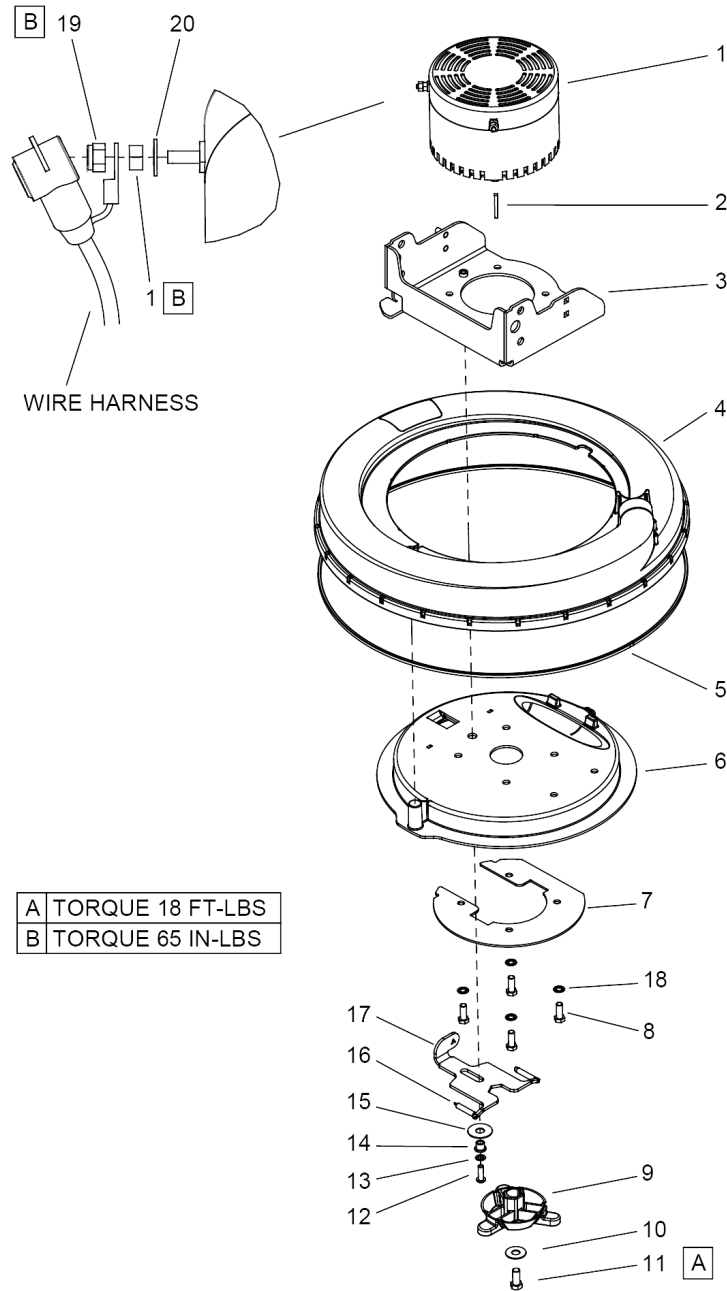

## 80 BURNISHING DECK (0.250-377.0)

POS	Article no.	Description	Quantity	Unit
-	8.634-801.0	Brush set	1.000	ST
1	8.635-498.0	MOTOR, 36VDC 3 HP 2000RPM	1.000	ST
2	8.628-685.0	KEY, 3/16 X 3/16 X 1.5 LCST GR1018	1.000	ST
3	8.635-347.0	BRACKET, MOTOR LIFT	1.000	ST
4	8.635-291.0	SHROUD, OUTER	1.000	ST
5	8.635-378.0	Brush	1.000	ST
6	8.635-290.0	SHROUD, INNER	1.000	ST
7	8.635-375.0	PLATE, SUPPORT, INNER SHROUD	1.000	ST
8	8.627-692.0	SCREW, 3/8-16 X 1 HHCS SS NP	4.000	ST
9	8.637-214.0	HUB, PAD DRIVER	1.000	ST
10	8.601-071.0	WASHER, 7/16 FLT STL YW ZNPLT	1.000	ST
11	8.627-754.0	SCREW, 7/16-20 X 1 HHCS STL GR5 ZNPLT	1.000	ST
12	8.600-693.0	SCREW, 5/16-18 X 1 SCHBTNHCS SS	1.000	ST
13	8.633-099.0	WASHER, 5/16 INTLK SS	1.000	ST
14	8.622-884.0	BUSHING, .314 X .502 X .5 FLG	1.000	ST
15	8.627-903.0	WASHER, .515 X 1.47 X .05 FLT NYL	1.000	ST
16	8.600-791.0	Spring EXT .31D X 2.0L X .03W	2.000	ST
17	8.635-376.0	BRACKET, MOTOR LOCK	1.000	ST
18	8.627-911.0	WASHER, 3/8 INTLK	4.000	ST
19	8.627-191.0	Nut 5/16-18 FLEX LK STL GRA ZNPLT	2.000	ST
20	8.601-067.0	WASHER, 5/16 FLT SS	2.000	ST

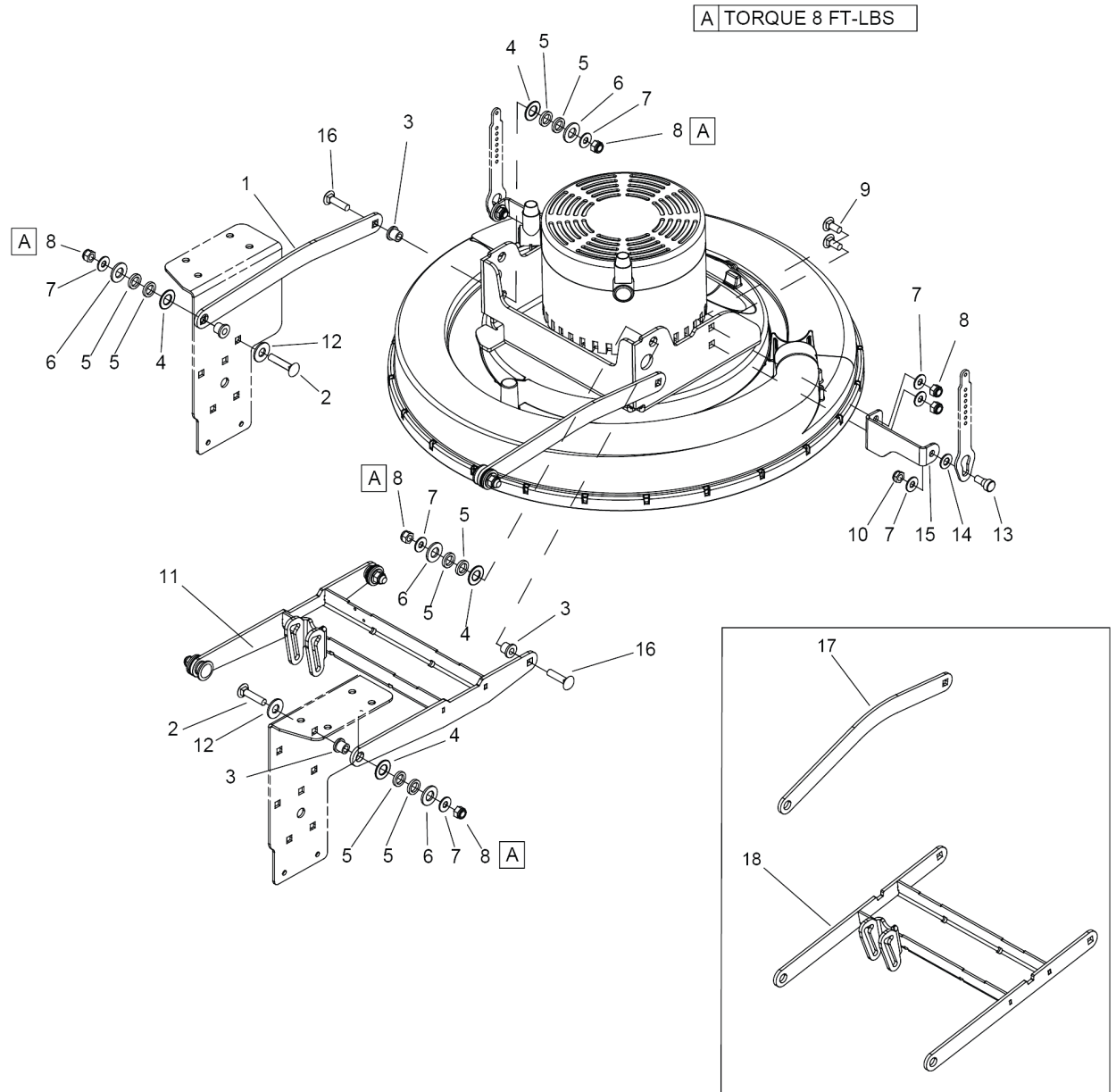

SEE SERIAL NUMBER PAGE FOR REFERENCE



90 BURNISHING DECK MOUNTING (0.250-378.0)

POS	Article no.	Description	Quantity	Unit	Serial number from
1	8.638-852.0	DECK LINKAGE ARM	2.000	ST	(5*)
2	8.627-747.0	SCREW, 5/16-18 X 1.5 CARR SS	4.000	ST	
3	8.622-884.0	BUSHING, .314 X .502 X .5 FLG	8.000	ST	
4	8.625-941.0	WASHER, .51 X 10 X .063 THR	8.000	ST	
5	8.627-935.0	WASHER, 1/2 X .771 X .013 WV	16.000	ST	
6	8.625-942.0	WASHER, .510 X 1 THR	8.000	ST	
7	8.601-067.0	WASHER, 5/16 FLT SS	14.000	ST	
8	8.627-083.0	NUT, 5/16-18 HEX NYLOCK SS	12.000	ST	
9	8.627-607.0	SCREW, 5/16-18 X .75 CARR SS	2.000	ST	
10	8.627-184.0	NUT, 5/16-18 HEXTHIN NYLOCK SS	2.000	ST	
11	8.638-850.0	TOP LINK ASSY	1.000	ST	(5*)
12	8.601-077.0	WASHER, 7/16 X1 X .08 FLT SS	4.000	ST	
13	8.635-381.0	SHOULDER BOLT, 3/8 X .25L SS	2.000	ST	
14	8.601-068.0	WASHER, 3/8 NYL	2.000	ST	
15	8.635-380.0	Holder	2.000	ST	
16	8.627-703.0	SCREW, 5/16-18 X 1.25 CARR SS	4.000	ST	
17	8.635-379.0	BRACKET, LINKAGE ARM	2.000	ST	
18	8.635-374.0	BRACKET, LIFT ASSY, TOP	1.000	ST	

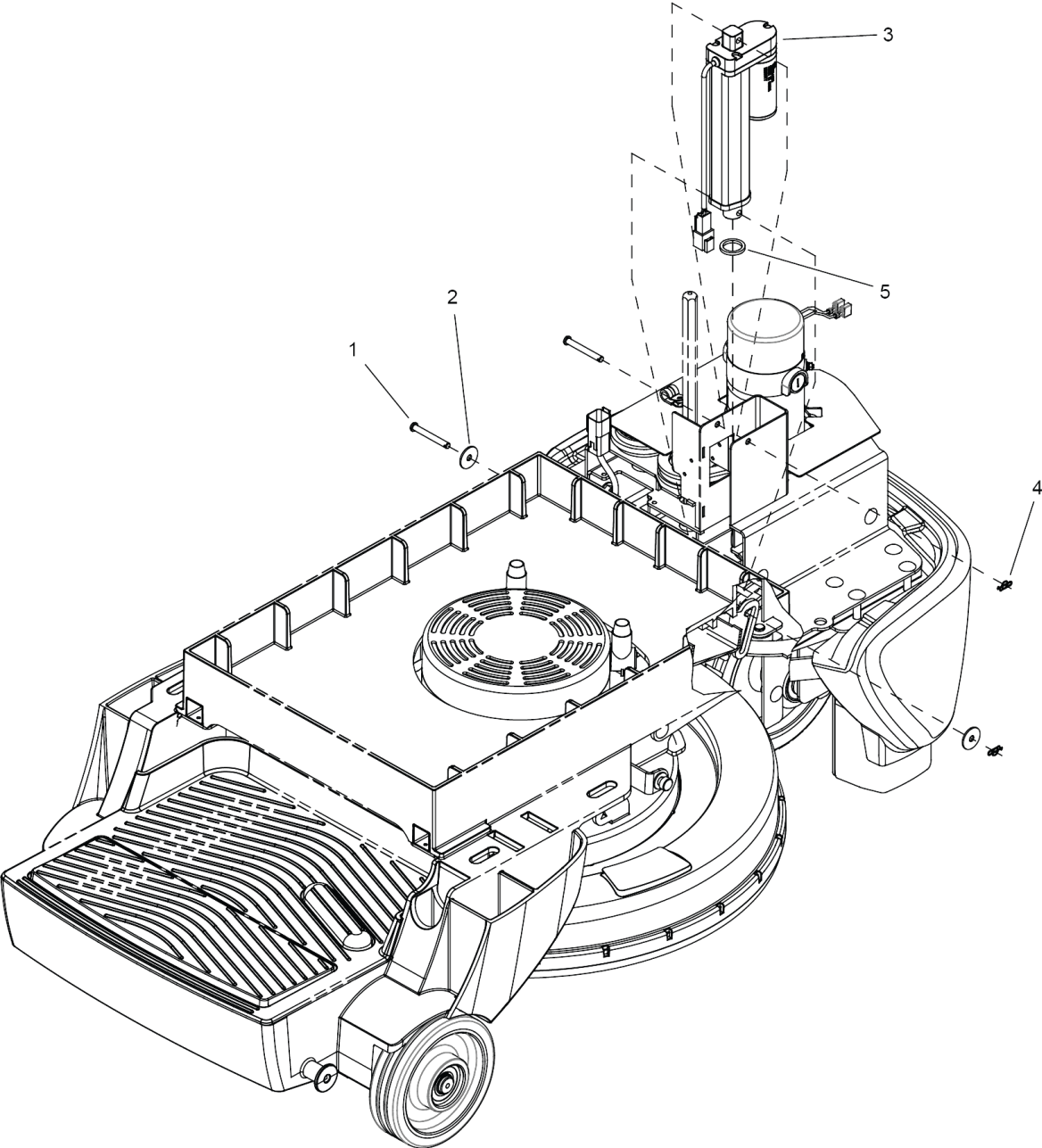

100 BURNISHING DECK LIFT (0.250-379.0)

---

POS	Article no.	Description	Quantity	Unit
1	8.632-804.0	PIN, CLEVIS 1/4 X 2 STL ZNPLT	2.000	ST
2	8.635-475.0	WASHER, .264 X 1 X .07 NYL BLK	2.000	ST
3	8.632-088.0	ACT, 36VDC, 3.0" STK, 8.74 LNG	1.000	ST
4	8.600-865.0	PIN, COTTER RING 1/4 X .041 X .844	2.000	ST
5	8.634-224.0	SPACER, .81 X 1.06 X .125	1.000	ST

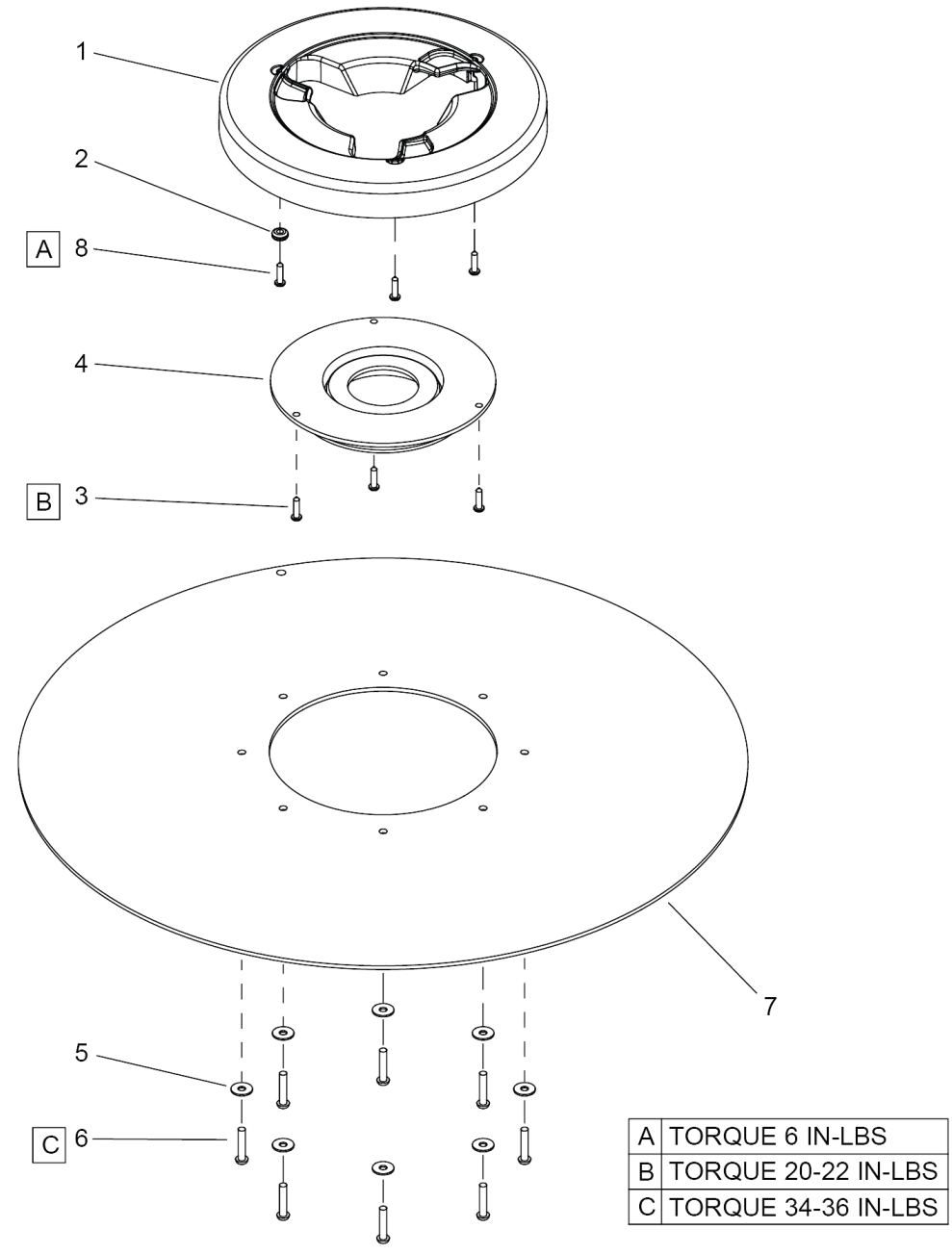

110 BURNISHING DECK - PAD DRIVER (0.250-392.0)

POS	Article no.	Description	Quantity	Unit
1	8.635-246.0	HUB, PAD DRIVER	1.000	ST
2	8.635-565.0	GROMMET, .155ID X .438OD X .188T	1.000	ST
3	8.617-314.0	SCREW, KA40 X 10 OVHCS STL WIN1412 ZNPLT	3.000	ST
4	8.635-562.0	RETAINER, PAD CENTER LOCK	1.000	ST
5	8.617-333.0	WASHER, M5 SS ISO7093	8.000	ST
6	8.632-791.0	SCREW, KA50 X 25 PTOVHS STL WN1412 ZNPLT	8.000	ST
7	8.635-561.0	Pad drive	1.000	ST
8	8.635-845.0	ASM, PAD DRIVER iGLOSS 20	1.000	ST
	<b>Item text1:</b> NOT SHOWN			
8	8.635-166.0	SCREW, 6-19 X .5 PHPNHSMS HL STL ZNPLT	3.000	ST

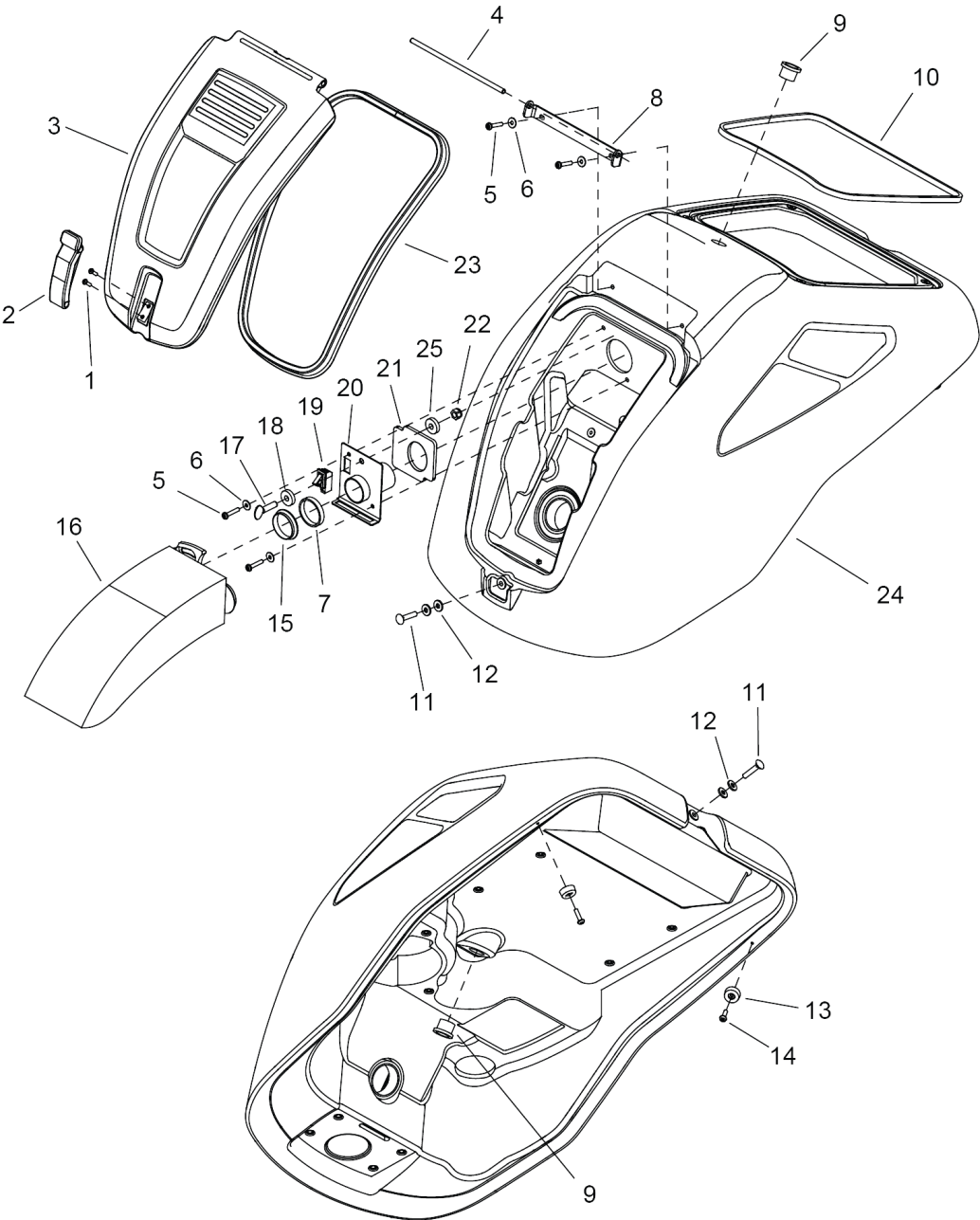

120 CONSOLE - BAG ENCLOSURE (0.250-393.0)

POS	Article no.	Description	Quantity	Unit
1	8.617-314.0	SCREW, KA40 X 10 OVHCS STL WIN1412 ZNPLT	2.000	ST
2	8.616-180.0	LATCH & CONCEALED KEEPER	1.000	ST
3	8.636-843.0	COVER, BAG ENCL, BLK	1.000	ST
4	8.635-365.0	SHAFT, .25 X 7.3, SS	1.000	ST
5	8.627-581.0	SCREW, 10-32 X 1 PHPNHMS STL BLKOX	4.000	ST
6	8.601-065.0	WASHER, .203 X .562 X .040 FLT	4.000	ST
7	8.635-926.0	WASHER, 1.5 X 1.7 X .19 NPRN	1.000	ST
8	8.635-317.0	BRKT, HINGE	1.000	ST
9	8.622-879.0	BUSHING, .753 X .875 X .75 FLG	2.000	ST
10	8.632-783.0	GASKET,.188X.31X41.0	1.000	ST
11	8.627-633.0	SCREW, 1/4-20 X 1.25 CARR	2.000	ST
12	8.627-952.0	WASHER, 1/4 FLT STL BLK ZNPLT	4.000	ST
13	8.635-613.0	BUMPER, 7/8OD X 13/32H, RUBBER	2.000	ST
14	8.600-660.0	SCREW, 10-16 X .75 PHPNH HL SS	2.000	ST
15	8.635-464.0	WASHER, 1.5ID SINK, RUBBER	1.000	ST
16	8.633-398.0	FILTER BAG (10/PK)	1.000	ZST
17	8.600-704.0	SCREW, 5/16-18 X 1 THUMB SS	1.000	ST
18	8.635-682.0	WASHER, .315 X .89 X .215 NYL	1.000	ST
19	8.632-768.0	SWITCH, INTERLOCK	1.000	ST
20	8.635-459.0	BRACKET, BAG MOUNT	1.000	ST
21	8.635-463.0	GASKET, BAG MOUNT	1.000	ST
22	8.627-184.0	NUT, 5/16-18 HEXTHIN NYLOCK SS	1.000	ST
23	8.635-366.0	GASKET, BAG COVER, 43.6"	1.000	ST
24	8.636-680.0	CONSOLE, IGLOSS 20 TRIMMED GRAY	1.000	ST
		<b>Item text1:</b> ACTIVE DUST CONTROL		
24	8.639-950.0	CONSOLE, PASSIVE, TRIMMED	1.000	ST
		<b>Item text1:</b> PASSIVE DUST CONTROL		
25	8.600-832.0	WASHER, .315 X .6 X .36 NYL	1.000	ST

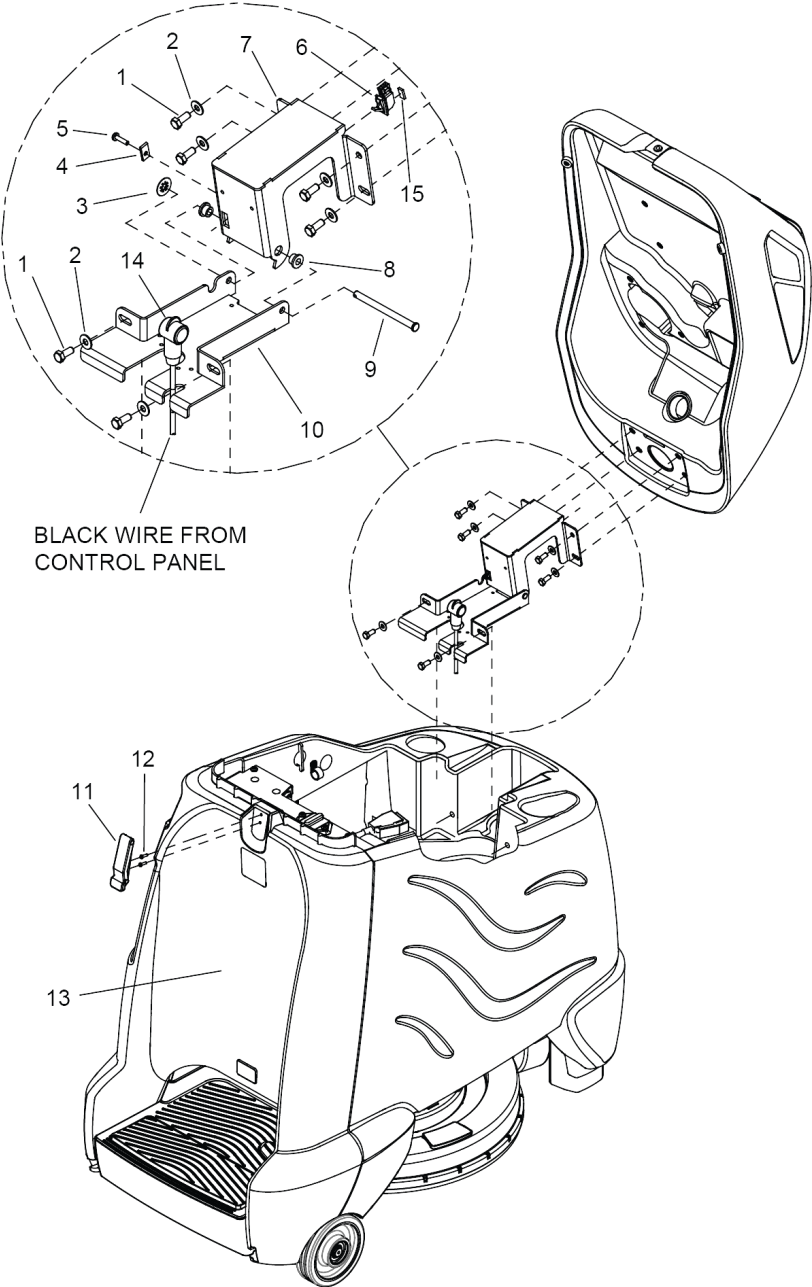



130 CONSOLE - HINGE (0.250-394.0)

POS	Article no.	Description	Quantity	Unit
1	8.627-678.0	SCREW, 5/16-18 X .75 HHCS SS	6.000	ST
2	8.601-067.0	WASHER, 5/16 FLT SS	6.000	ST
3	8.632-886.0	NUT, 5/16 PUSH LK STL ZNPLT	1.000	ST
4	8.627-086.0	NUT, 10-24 TYPEU BLK	1.000	ST
5	8.627-711.0	SCREW, 10-24 X .75 PHPNHMS SS	1.000	ST
6	8.632-768.0	SWITCH, INTERLOCK	1.000	ST
7	8.632-632.0	BRACKET, HINGE UPPER	1.000	ST
8	8.622-899.0	BUSHING, .314 X .502 X .375 FLG BRZ	2.000	ST
9	8.632-634.0	PIN, CLEVIS 5/16 X 4 STL ZNPLT	1.000	ST
10	8.635-501.0	BRKT, HINGE LOWER	1.000	ST
11	8.616-180.0	LATCH & CONCEALED KEEPER	1.000	ST
12	8.617-314.0	SCREW, KA40 X 10 OVHCS STL WIN1412 ZNPLT	2.000	ST
13	8.636-836.0	PANEL, BACK TRIMMED, BLK	1.000	ST
14	8.600-892.0	BOOT, RUBBER TERM. ISOLATOR	1.000	ST

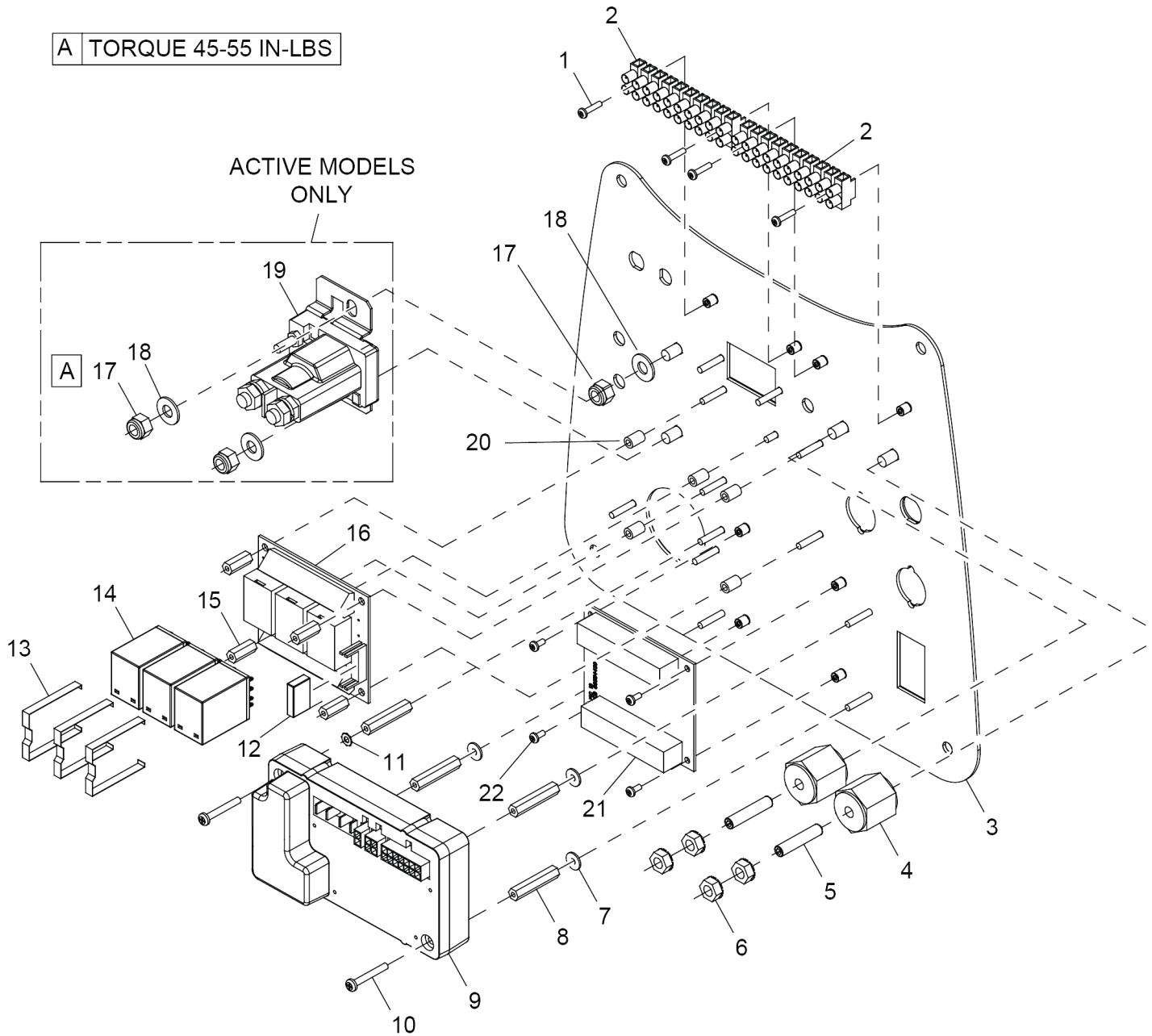

140 CONTROL PANEL 1 (0.250-395.0)

POS	Article no.	Description	Quantity	Unit	Serial number from	Serial number to
1	8.627-526.0	SCREW, 4-40 X .5 PHPNHMS STL ZNPLT	4.000	ST		
2	8.632-639.0	CONN, 8MM PITCH, 10 POS	2.000	ST		
3	8.635-249.0	PANEL, CONTROL iGLOSS 20	1.000	ST		
4	8.625-591.0	STANDOFF, 1/4-20 X 1.0 HEX INS	2.000	ST		
5	8.600-685.0	SCREW, 1/4-20 X 1.25 SCHSET CP SS	1.000	ST		
6	8.600-571.0	NUT, 1/4-20 HEXSTRW LK STL ZNPLT	4.000	ST		
7	8.627-945.0	WASHER, 6 FLT STL ZNPLT	3.000	ST		
8	8.635-486.0	Standoff	4.000	ST		
9	8.638-597.0	Controller C2B	1.000	ST	(*3)	
9	8.635-632.0	CONTROLLER, iGLOSS 20	1.000	ST		(3*)
10	8.627-555.0	SCREW, 6-32 X 1.25 PHPNHMS STL ZNPLT	2.000	ST		
11	8.627-902.0	WASHER, 6 EXTLK SS	1.000	ST		
12	8.633-611.0	RELAY, SPST-NO	1.000	ST		
13	8.633-610.0	CLIP, RELAY	3.000	ST		
14	8.631-390.0	RELAY, 5A, 24V, 4PDT	3.000	ST		
15	8.625-590.0	STANDOFF, 6-32 X 5/8 HEX NYL	4.000	ST		
16	8.633-609.0	CIRCUIT BOARD, 4 RELAY	1.000	ST		
17	8.600-581.0	NUT, 1/4-20 HEX NYLOCK SS	1.000	ST		
		<b>Item text1:</b> ACTIVE MODEL - QTY 2				
		<b>Item text2:</b> PASSIVE MODEL - QTY 1				
18	8.601-063.0	WASHER, 1/4 SS	1.000	ST		
		<b>Item text1:</b> ACTIVE MODEL - QTY 2				
		<b>Item text2:</b> PASSIVE MODEL - QTY 1				
19	8.625-136.0	Relay 36VDC 100A	1.000	ST		
		<b>Item text1:</b> ACTIVE MODEL ONLY				
20	8.633-721.0	SPACER, .14ID X .28OD X .38, NYL	5.000	ST		
21	8.635-443.0	PCBA, ROTARY SWITCH	1.000	ST		
22	8.627-457.0	SCREW, 4-40 X .25 PHPNHMS STL ZNPLT	4.000	ST		

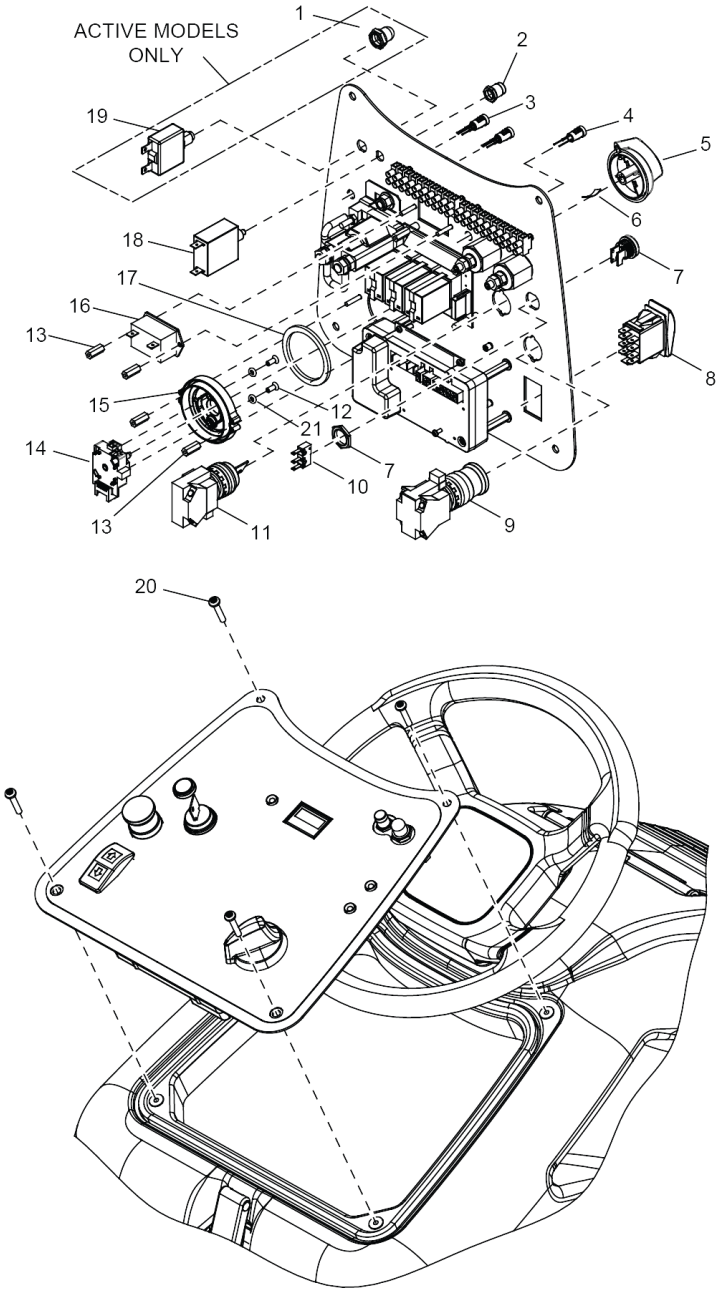

150 CONTROL PANEL 2 (0.250-402.0)

POS	Article no.	Description	Quantity	Unit
1	8.633-251.0	BOOT, SEAL PUSH BUTTON 11MM	1.000	ST
	<b>Item text1:</b> ACTIVE MODEL ONLY			
2	8.600-126.0	BOOT, CB 3/8-32 UNS	1.000	ST
3	8.634-864.0	LED, BAG FULL INDICATOR	2.000	ST
4	8.634-896.0	LED, BATTERY INDICATOR	1.000	ST
5	5.321-738.0	Handhold operational concept	1.000	ST
6	6.313-014.0	Spring element	1.000	ST
7	8.629-520.0	ASM, BUTTON, BLACK, W/BEZEL	1.000	ST
8	8.631-395.0	SWITCH, SPDT 3 POSN MOM, ARROW	1.000	ST
9	8.629-259.0	SWITCH, E-STOP AKW CHARIOT	1.000	ST
10	8.629-278.0	SWITCH, MICRO	1.000	ST
11	8.600-717.0	Switch KEY TWO POSITION	1.000	ST
12	8.635-843.0	SCREW, M4 X 12 FLHMS SS ISO7046 NP	2.000	ST
13	8.625-590.0	STANDOFF, 6-32 X 5/8 HEX NYL	4.000	ST
14	8.635-487.0	SWITCH, ROTARY	1.000	ST
15	8.635-456.0	BEZEL, ROTARY SWITCH	1.000	ST
16	8.631-547.0	METER, HOUR ICD	1.000	ST
17	8.635-481.0	GASKET, ROTARY SWITCH	1.000	ST
18	8.635-368.0	BREAKER, 1.5A CARLING MAGNETIC	1.000	ST
19	8.631-616.0	BREAKER, 18A, 250VAC, 32VDC	1.000	ST
	<b>Item text1:</b> ACTIVE MODEL ONLY			
20	8.637-141.0	SCREW, 10-32 X .75 TMS SS BLK	4.000	ST
21	8.635-844.0	O-RING, 4MM ID, 1.5MM THK, BUNA-N	2.000	ST

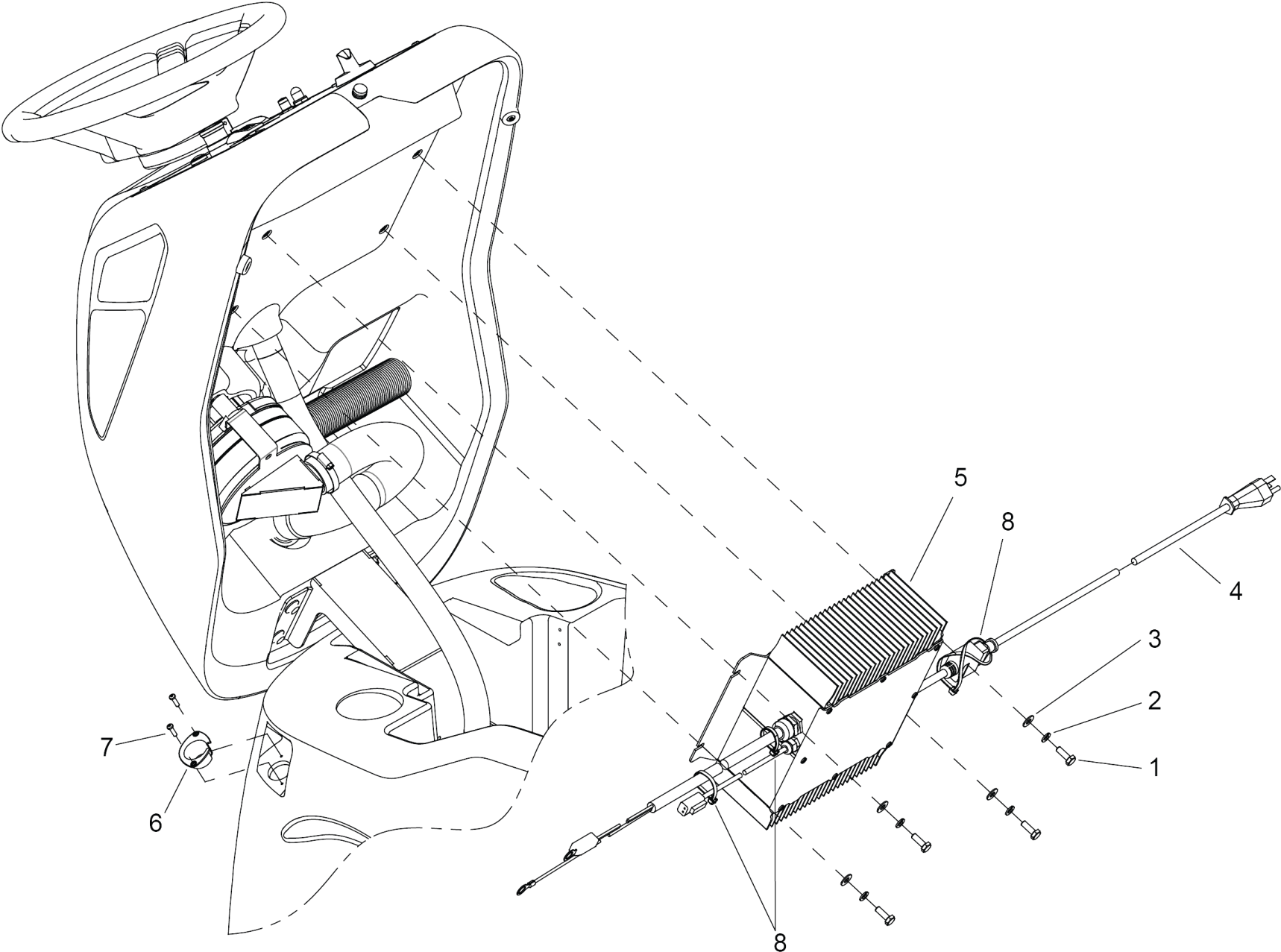

160 CHARGER - OPTIONAL (0.250-403.0)

POS	Article no.	Description	Quantity	Unit
1	8.627-378.0	SCREW, 1/4-20 X .75 HHCS SS NP	4.000	ST
2	8.601-078.0	WASHER, 1/4 SPL STL ZNPLT	4.000	ST
3	8.601-063.0	WASHER, 1/4 SS	4.000	ST
4	8.623-439.0	CORD ASM, 16/3 SJTW X 2M IEC	1.000	ST
5	8.635-330.0	CHRGR, 36V 21A OBC ALG 1	1.000	ST
6	8.634-443.0	GROMMET, CHARGE PLUG	1.000	ST
7	8.617-314.0	SCREW, KA40 X 10 OVHCS STL WIN1412 ZNPLT	2.000	ST
8	8.626-494.0	Cable tie 11.38" UL/CSA	3.000	ST

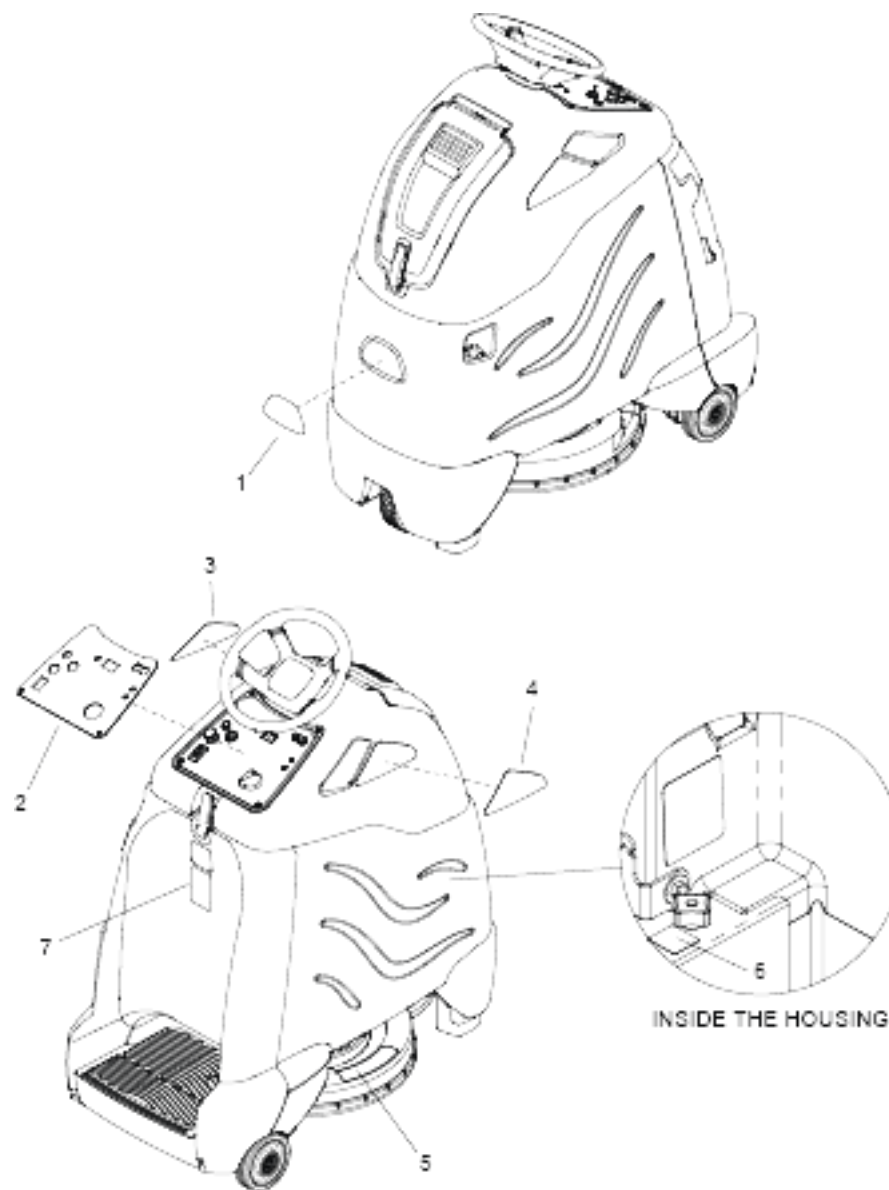

SEE SERIAL NUMBER PAGE FOR REFERENCE



170 DECALS (0.250-404.0)

POS	Article no.	Description	Quantity	Unit	Serial number from
1	8.633-500.0	LABEL, AKW LOGO DOMED	1.000	ST	
2	8.639-562.0	LABEL, PANEL iGLOSS 20	1.000	ST	
		<b>Item text1:</b> PASSIVE MODELS			
2	8.639-561.0	LABEL, PANEL, iGLOSS 20, DLX	1.000	ST	
		<b>Item text1:</b> ACTIVE MODELS			
3	8.639-563.0	LABEL, IGLOSS 20 LEFT	1.000	ST	
4	8.639-564.0	LABEL, IGLOSS 20 RIGHT	1.000	ST	
5	8.639-680.0	LABEL, BURNISHER SHROUD	1.000	ST	
6	8.638-508.0	LABEL, MANUAL	1.000	ST	(3*)
7	8.643-126.0	Label QR code iGloss 20	1.000	ST	

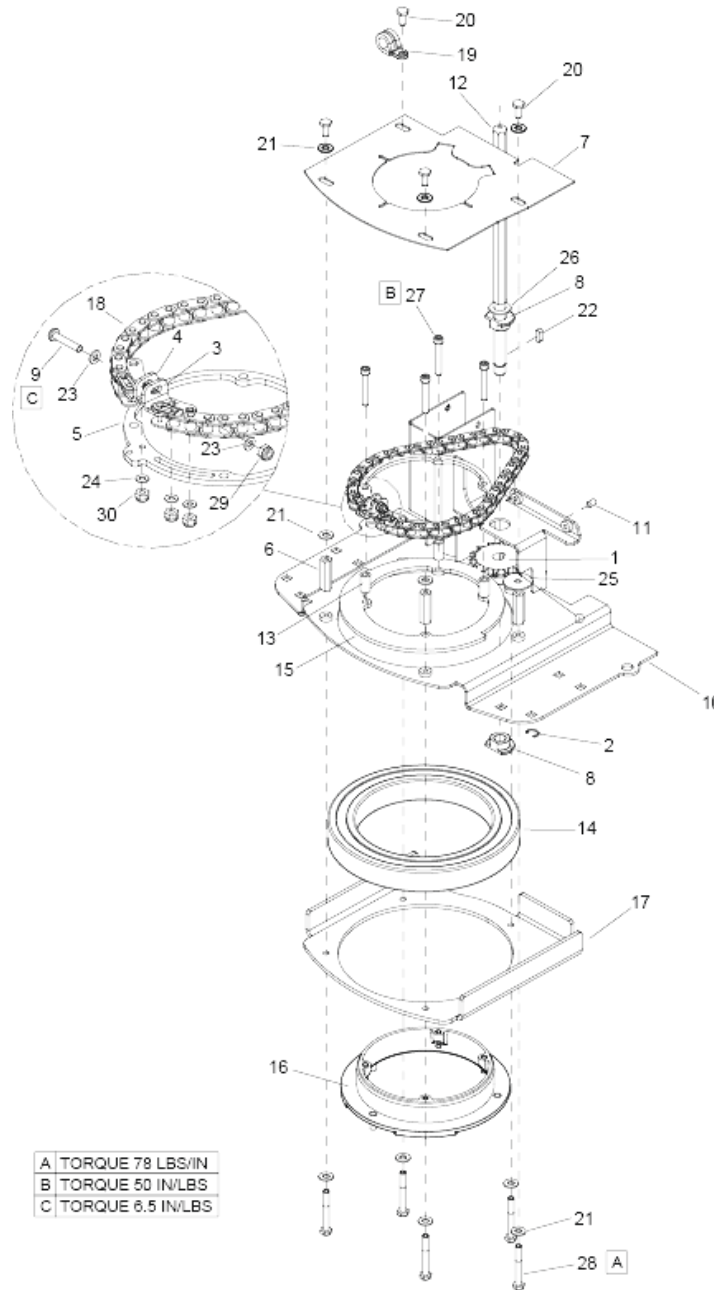

180 SLEW/STEERING-FROM SERIAL NUMBER (3\*) (0.250-405.0)

POS	Article no.	Description	Quantity	Unit
1	8.641-014.0	Gear wheel ANSI 40 14T	1.000	ST
2	8.640-964.0	Clip .50 SHAFT SIDE RETAIN	1.000	ST
3	8.640-957.0	Angle joint chain	1.000	ST
4	8.640-956.0	Angle joint chain	1.000	ST
5	8.640-955.0	Support plate chain	1.000	ST
6	8.640-952.0	Nut 1/4-20 X 1.5 CPL SS	4.000	ST
7	8.640-882.0	Plate chain guide C2	1.000	ST
8	8.640-864.0	Flanged bushing .503X1.25X.470 FLG 'D'	2.000	ST
9	8.640-858.0	Screw 10-32 X 1 TPNHMS SS BLK ZNPLT	1.000	ST
10	8.640-559.0	Support plate control system	1.000	ST
11	8.600-661.0	SCREW, 1/4-20 X .25 SCHSET KCP BLKOX	1.000	ST
12	8.640-556.0	SHAFT, STEERING SPROCKET	1.000	ST
13	8.640-551.0	Distance holder .25ID X .430OD X.83LG	4.000	ST
14	8.640-549.0	Bearing control system C2	1.000	ST
15	8.640-548.0	Plate C2	1.000	ST
16	8.640-547.0	Bearing screw connector bottom	1.000	ST
17	8.640-546.0	Plate c2	1.000	ST
18	8.640-534.0	Chain ANSI#40 X 21.5" W/2 MASTER	1.000	ST
19	8.636-387.0	CLAMP, 5/8" OD CUSHIONED	1.000	ST
20	8.627-383.0	SCREW, 1/4-20 X .5 HHCS SS NP	4.000	ST
21	8.601-063.0	WASHER, 1/4 SS	13.000	ST
22	8.632-671.0	KEY, 5 X 5 X 16MM CS GR1045	1.000	ST
23	8.627-919.0	WASHER, 10 FLT STL ZNPLT	2.000	ST
24	8.627-899.0	WASHER, 8 FLT	3.000	ST
25	8.627-894.0	WASHER, 1/4 STL ZNPLT	2.000	ST
26	8.627-885.0	WASHER, .506 X .94 X .06 NYL	1.000	ST
27	8.627-539.0	Screw 1/4-20 X 1.625 SCHCS STL ZNPLT	4.000	ST
28	8.627-385.0	SCREW, 1/4-20 X 2 HHCS SS	5.000	ST
29	8.627-099.0	NUT, 10-32 HEX NYLOCK SS	1.000	ST
30	8.627-085.0	NUT, 8-32 HEX NYLOCK SS	3.000	ST

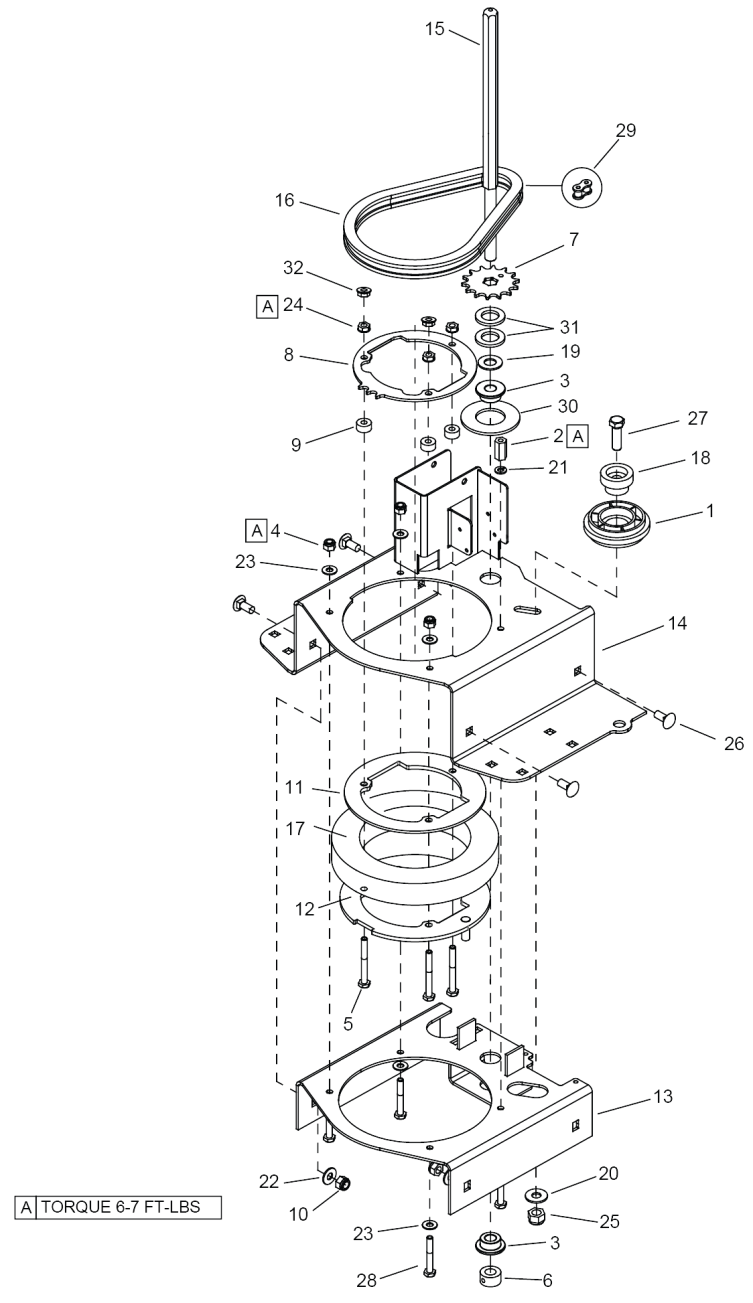

190 DRIVE-CHAIN PRIOR TO SERIAL NUMBER (3\*) (0.250-406.0)

POS	Article no.	Description	Quantity	Unit
1	8.633-072.0	CHAIN TENSIONNER	1.000	ST
2	8.632-935.0	NUT, 1/4-20 CPL SS	1.000	ST
3	8.632-805.0	BUSHING, .480 X 1.25 X .485 FLG	2.000	ST
4	8.600-581.0	NUT, 1/4-20 HEX NYLOCK SS	3.000	ST
5	8.627-310.0	SCREW, 1/4-20 X 2.25 HHCS STL GR5 ZNPLT	3.000	ST
6	8.632-206.0	COLLAR, 12MM ID	1.000	ST
7	8.632-205.0	SPROCKET, STEERING, 14T	1.000	ST
8	8.632-204.0	Retaining plate	1.000	ST
9	8.632-203.0	Spacer	3.000	ST
10	8.627-083.0	NUT, 5/16-18 HEX NYLOCK SS	7.000	ST
11	8.631-974.0	PLATE, UPPER CLAMP	1.000	ST
12	8.631-968.0	PLATE, LOWER CLAMP	1.000	ST
13	8.631-961.0	BRACKET, BEARING CLAMP	1.000	ST
14	8.631-960.0	BRACKET, DRIVE MOUNT	1.000	ST
15	8.631-959.0	SHAFT, STEERING SPROCKET	1.000	ST
16	8.631-956.0	CHAIN, ISO 08B, 12.7MM PITCH	1.000	ST
17	8.601-444.0	BEARING DRIVE	1.000	ST
18	8.622-427.0	SLEEVE, CHAIN TENSIONER	1.000	ST
19	8.625-943.0	WASHER, M12 FLT	1.000	ST
20	8.627-951.0	WASHER, 3/8 FLT STL ZNPLT	1.000	ST
21	8.601-078.0	WASHER, 1/4 SPL STL ZNPLT	1.000	ST
22	8.601-067.0	WASHER, 5/16 FLT SS	4.000	ST
23	8.601-063.0	WASHER, 1/4 SS	7.000	ST
24	8.600-571.0	NUT, 1/4-20 HEXSTRW LK STL ZNPLT	3.000	ST
25	8.627-193.0	NUT HEX NYL LOC 3/8-16	1.000	ST
26	8.627-607.0	SCREW, 5/16-18 X .75 CARR SS	4.000	ST
27	8.627-519.0	SCREW, 3/8-16 X 1.25 HHCS SS	1.000	ST
28	8.627-415.0	SCREW, 1/4-20 X 1.75 HHCS STL GR5 ZNPLT	4.000	ST
29	8.623-278.0	Chain MASTERLINK 12.7MM	1.000	ST
30	8.636-860.0	X-REF TO 8.632-656.0 8/16	1.000	ST
31	8.627-942.0	WASHER, .765 X 1.25 X .08 FLT NYL	2.000	ST
32	8.627-137.0	NUT, 1/4-20 SERFLG STL ZNPLT	2.000	ST

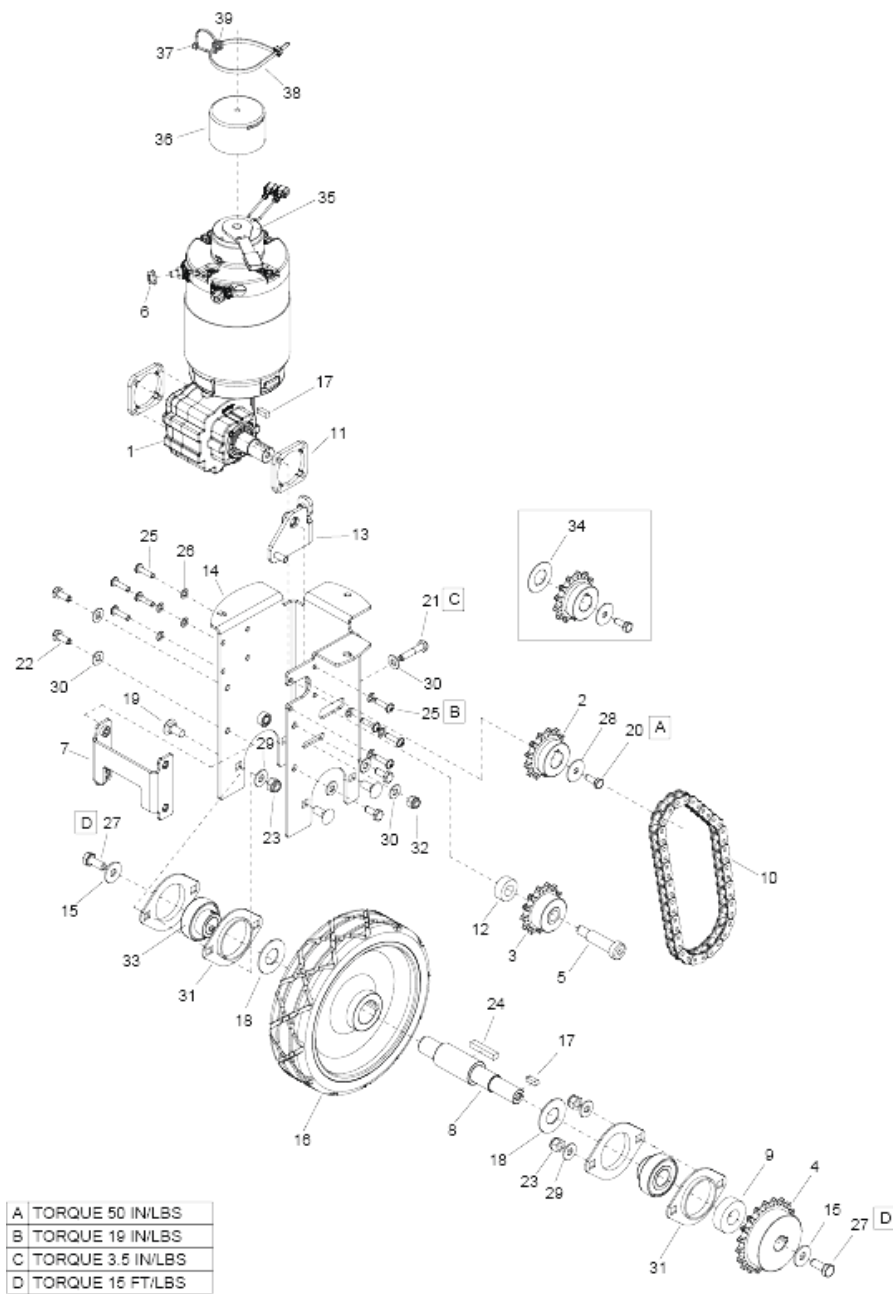

## 200 DRIVE LOWER - FROM SERIAL NUMBER (3\*) (0.250-411.0)

POS	Article no.	Description	Quantity	Unit	Serial number from
1	8.641-117.0	Traction motor C2	1.000	ST	(4*)
2	8.640-996.0	Chain wheel transmission ANSI 40 13T	1.000	ST	
3	8.640-995.0	Chain wheel transmission ANSI 40 13T IDLER	1.000	ST	
4	8.640-994.0	Chain wheel transmission ANSI 40 20T	1.000	ST	
5	8.640-591.0	Bolt 1/2 x 1.625	1.000	ST	
6	8.638-411.0	Nut M6-1, HEX, SERFLG, DIN6923	2.000	ST	
7	8.640-539.0	Retaining plate C2	1.000	ST	
8	8.640-538.0	Axle drive wheel	1.000	ST	
9	8.640-537.0	Distance holder C2	1.000	ST	
10	8.640-536.0	Chain ANSI#40 X 21" W/MASTER	1.000	ST	
11	8.640-535.0	Distance holder C2 MTR MNT HOUSING	2.000	ST	
12	8.640-533.0	Distance holder C2	1.000	ST	
13	8.640-532.0	Retaining plate C2	1.000	ST	
14	8.640-531.0	Housing transmission C2	1.000	ST	
15	7.312-289.0	Washer 8 -A2 ISO 7093-1	2.000	ST	
16	8.636-917.0	Wheel 8.00 x 2.00, GRAY X-GRV	1.000	ST	
17	8.632-671.0	KEY, 5 X 5 X 16MM CS GR1045	2.000	ST	
18	8.632-167.0	WASHER, .748 SS	2.000	ST	
19	8.627-607.0	SCREW, 5/16-18 X .75 CARR SS	4.000	ST	
20	8.627-470.0	SCREW, M6 X 1 X 16 HHCS ZNPLT	1.000	ST	
21	8.627-462.0	SCREW, 1/4-20 X 1.25 HHMS STL GR5 ZNPLT	1.000	ST	
22	8.627-375.0	SCREW, 1/4-20 X .625 HHCS SS NP	4.000	ST	
23	8.627-083.0	NUT, 5/16-18 HEX NYLOCK SS	4.000	ST	
24	8.621-964.0	KEY, 1/4 X 1/4 X 1.5 LCSTL GR1018	1.000	ST	
25	8.638-412.0	Screw M5-0.8 X 16, TPNHMSSS	8.000	ST	
26	8.613-733.0	WASHER, M5 SHPRF STL ZNPLT	8.000	ST	
27	8.613-664.0	SCREW, M8-1.25 X 20 HHMS ZNPLT	2.000	ST	
28	8.601-081.0	WASHER, 1/4 FNDR SS	1.000	ST	
29	8.601-067.0	WASHER, 5/16 FLT SS	4.000	ST	
30	8.601-063.0	WASHER, 1/4 SS	6.000	ST	
31	8.600-861.0	Flanged bearing PRESS STEEL	4.000	ST	
32	8.600-581.0	NUT, 1/4-20 HEX NYLOCK SS	1.000	ST	
33	8.600-103.0	BEARING, 3/4 SPH BALL	2.000	ST	

200 DRIVE LOWER - FROM SERIAL NUMBER (3\*) (0.250-411.0)

POS	Article no.	Description	Quantity	Unit	Serial number from
34	8.640-554.0	Spacer sleeve C2	1.000	ST	
35	8.638-691.0	Brake traction motor C2	1.000	ST	
36	8.642-686.0	Environmental brake cover	1.000	ST	(6*)
37	8.626-493.0	CABLE TIE, 3.5" UL/CSA	1.000	ST	(7*)
38	8.626-494.0	Cable tie 11.38" UL/CSA	1.000	ST	(7*)
39	8.638-441.0	Cable spacer cross	1.000	ST	(7*)



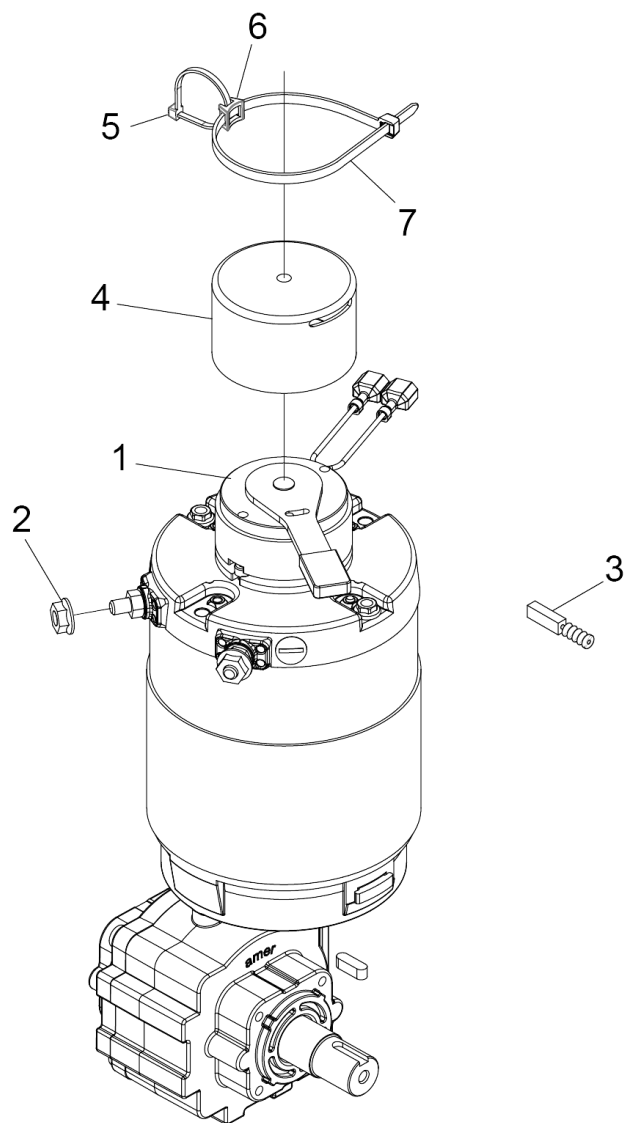

## 1 Traction motor C2 (8.641-117.0)

---

<b>POS</b>	<b>Article no.</b>	<b>Description</b>	<b>Quantity</b>	<b>Unit</b>
1	8.638-691.0	Brake traction motor C2	1.000	ST
2	8.638-411.0	Nut M6-1, HEX, SERFLG, DIN6923	2.000	ST
3	8.638-409.0	Carbon brush set AOMPI40	1.000	ST
4	8.642-686.0	Environmental brake cover	1.000	ST
5	8.626-493.0	CABLE TIE, 3.5" UL/CSA	1.000	ST
6	8.631-441.0	RELEASE BUTTON	1.000	ST
7	8.626-494.0	Cable tie 11.38" UL/CSA	1.000	ST

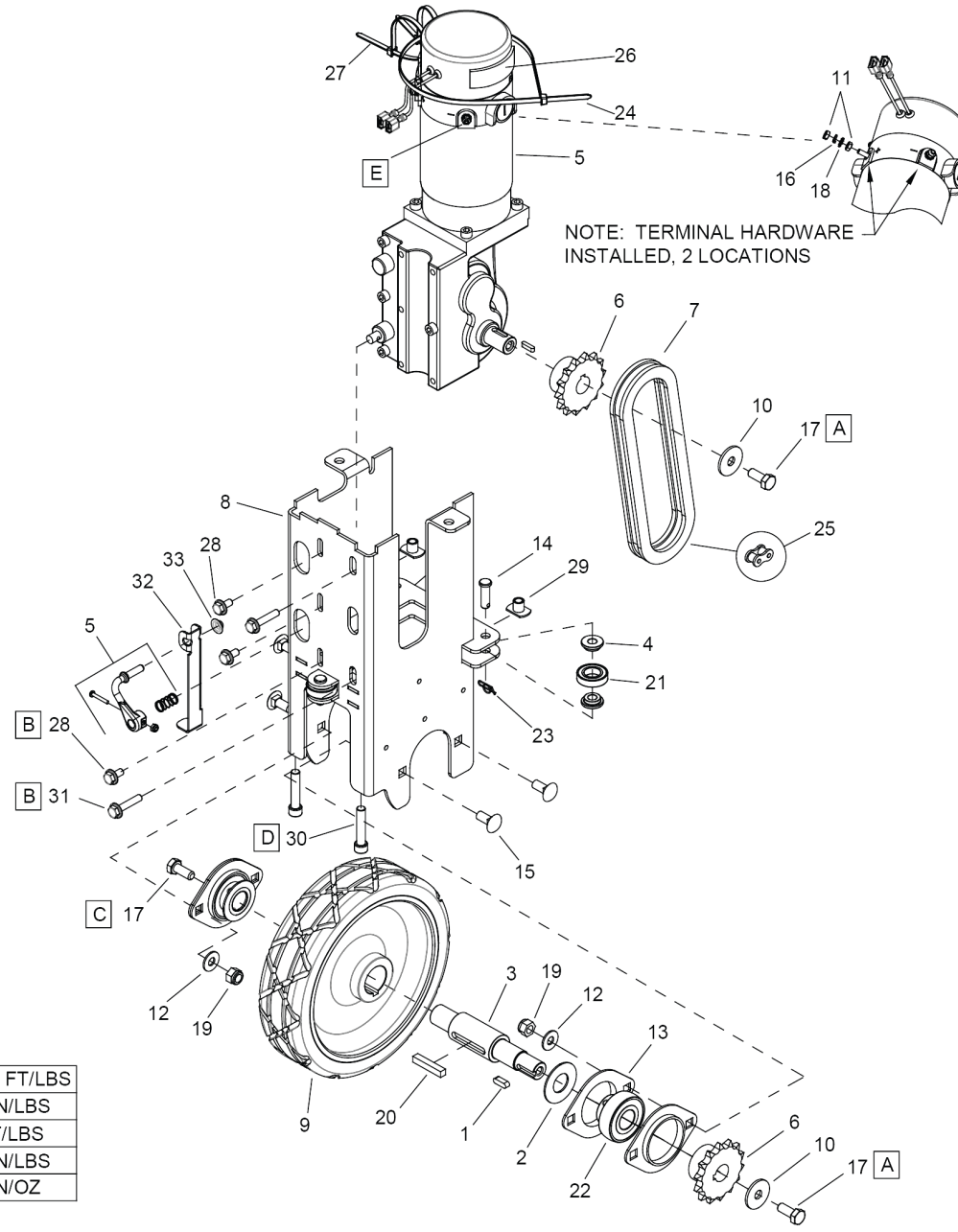

## 210 DRIVE-LOWER PRIOR TO SERIAL NUMBER (3\*) (0.250-412.0)

POS	Article no.	Description	Quantity	Unit
1	8.632-671.0	KEY, 5 X 5 X 16MM CS GR1045	1.000	ST
2	8.632-167.0	WASHER, .748 SS	2.000	ST
3	8.631-981.0	Axle drive wheel	1.000	ST
4	8.631-967.0	SLEEVE, BEARING	6.000	ST
5	8.637-844.0	KIT, BRUSHES, DRIVE MOTOR	1.000	ST
		<b>Item text1:</b> NOT SHOWN - CCL motor use 8.633-199.0		
		<b>Item text2:</b> Linix motor use 8.637-841.0		
5	8.636-984.0	KIT, BRAKE REPLACEMENT - SMALL STAND ON	1.000	ST
		<b>Item text1:</b> NOT SHOWN		
5	8.636-401.0	Wheel drive motor	1.000	ST
		<b>Item text1:</b> For installation of 8.636-401.0		
		<b>Item text2:</b> order kit 8.636-900.0		
6	8.631-965.0	SPROCKET, DRIVE, 14T	2.000	ST
7	8.631-964.0	CHAIN, ISO 08B, 12.7MM PITCH	1.000	ST
8	8.631-962.0	FRAME, LOWER DRIVE	1.000	ST
9	8.636-917.0	Wheel 8.00 x 2.00, GRAY X-GRV	1.000	ST
10	8.627-963.0	WASHER, 5/16 X 1.13 X .09 FLT	3.000	ST
11	8.628-850.0	NUT, M4X.7 HEX STL CL8 ZNPLT	4.000	ST
12	8.601-067.0	WASHER, 5/16 FLT SS	4.000	ST
13	8.600-861.0	Flanged bearing PRESS STEEL	4.000	ST
14	8.627-255.0	PIN, CLEVIS 5/16 X 1 STL ZNPLT	3.000	ST
15	8.627-607.0	SCREW, 5/16-18 X .75 CARR SS	4.000	ST
16	8.613-485.0	WASHER, M4 SPRL SS DIN127B	2.000	ST
17	8.613-664.0	SCREW, M8-1.25 X 20 HHMS ZNPLT	3.000	ST
18	8.637-223.0	WASHER, M4 EXTLK STL DIN6797 TYPEA ZNPLT	2.000	ST
19	8.627-083.0	NUT, 5/16-18 HEX NYLOCK SS	4.000	ST
20	8.621-964.0	KEY, 1/4 X 1/4 X 1.5 LCSTL GR1018	1.000	ST
21	8.633-238.0	ROLLER, 1.1 OD	3.000	ST
22	8.600-103.0	BEARING, 3/4 SPH BALL	2.000	ST
23	8.600-866.0	Cotter 5/16" RING	3.000	ST
24	8.600-283.0	Cable tie .375 X 24.7	1.000	ST
25	8.623-278.0	Chain MASTERLINK 12.7MM	1.000	ST
		<b>Item text1:</b> NOT SHOWN		

210 DRIVE-LOWER PRIOR TO SERIAL NUMBER (3\*) (0.250-412.0)

POS	Article no.	Description	Quantity	Unit
26	8.636-204.0	TAPE CLOSED CELL 1/8 X 3/4 X 2 1/2 PSA	2.000	ST
27	8.626-492.0	CABLE TIE, 7" UL/CSA	2.000	ST
28	8.636-214.0	SCREW, M6-1 X 12 HEXFLGHSERFLG STL ZNPLT	3.000	ST
29	8.634-849.0	NUT, 5/16-18 X .38 WLD TAB STL	2.000	ST
30	8.636-213.0	SCREW, 5/16-18 X 1.5 SCHCS SS	2.000	ST
31	8.636-215.0	SCREW, M6-1 X 30 HEXFLGHSERFLG STL ZNPLT	2.000	ST
32	8.633-387.0	LEVER, DRIVE ENGAGEMENT	1.000	ST
33	8.627-124.0	NUT, 1/4 PAL STL ZNPLT	1.000	ST

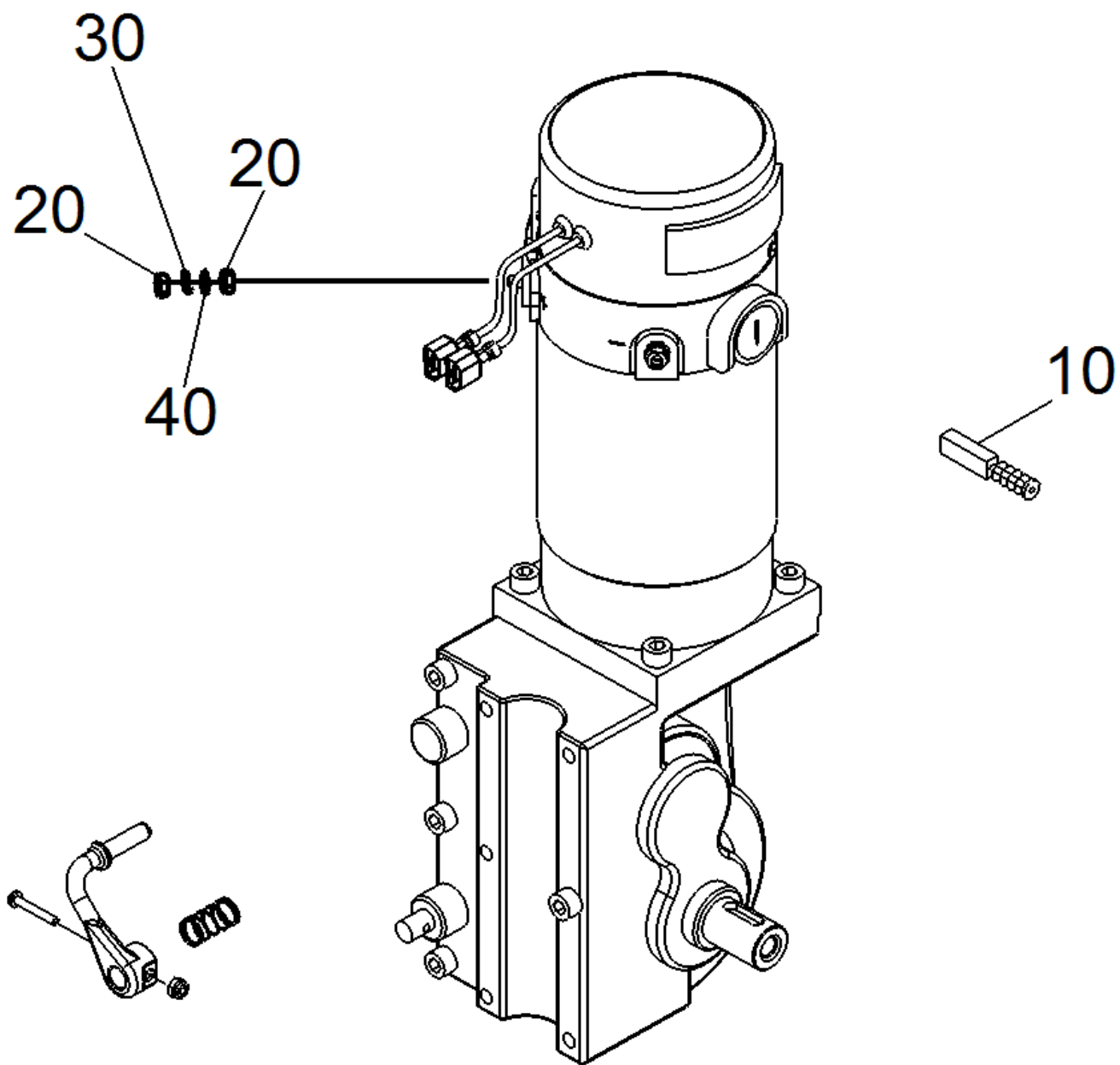

## 5 Wheel drive motor (8.636-401.0)

---

POS	Article no.	Description	Quantity	Unit
10	8.637-844.0	KIT, BRUSHES, DRIVE MOTOR	1.000	ST
20	8.628-850.0	NUT, M4X.7 HEX STL CL8 ZNPLT	4.000	ST
30	8.613-485.0	WASHER, M4 SPRL SS DIN127B	2.000	ST
40	8.637-223.0	WASHER, M4 EXTLK STL DIN6797 TYPEA ZNPLT	2.000	ST

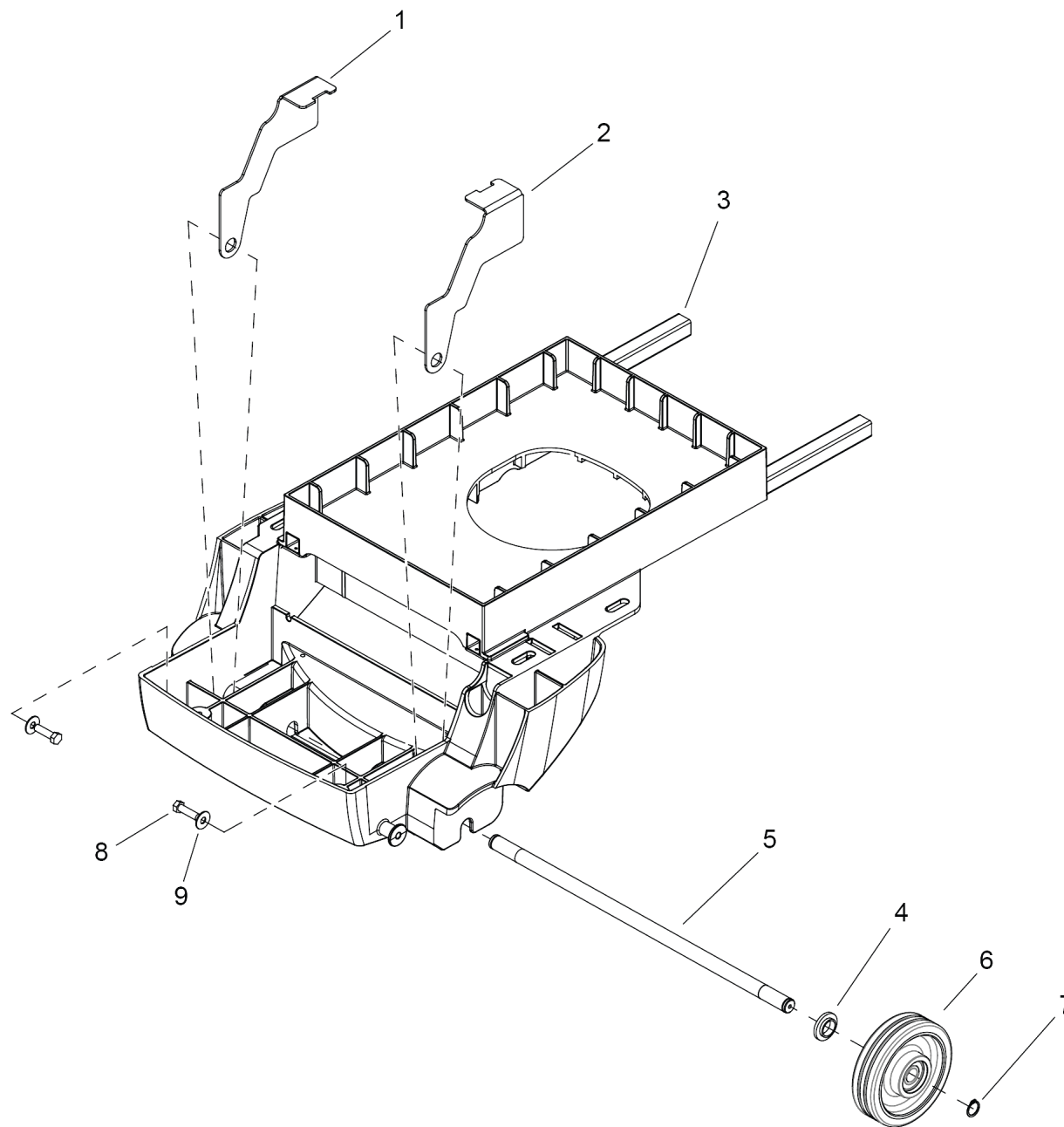



220 FRAME & REAR WHEELS (0.250-417.0)

POS	Article no.	Description	Quantity	Unit
1	8.632-626.0	BRACKET, FRAME LEFT	1.000	ST
2	8.632-625.0	BRACKET, FRAME RIGHT	1.000	ST
3	8.636-850.0	FRAME ASM, BLK	1.000	ST
	<b>Item text1:</b> INCLUDES ITEM 8 & 9			
4	8.632-622.0	SPACER, FLG, .887ID X 1.055OD X .345LG	2.000	ST
5	8.631-803.0	AXLE, 20MM X 562MM	1.000	ST
6	8.636-916.0	WHEEL, 6.00X1.58, GRY W/BEARINGS	2.000	ST
7	8.622-347.0	RING, 20MM EXTERNAL SNAP	2.000	ST
8	8.627-891.0	WASHER, 3/8 SS	2.000	ST
9	8.634-095.0	SCREW, 3/8 X 1.5 HHLS STL ZNPLT	2.000	ST

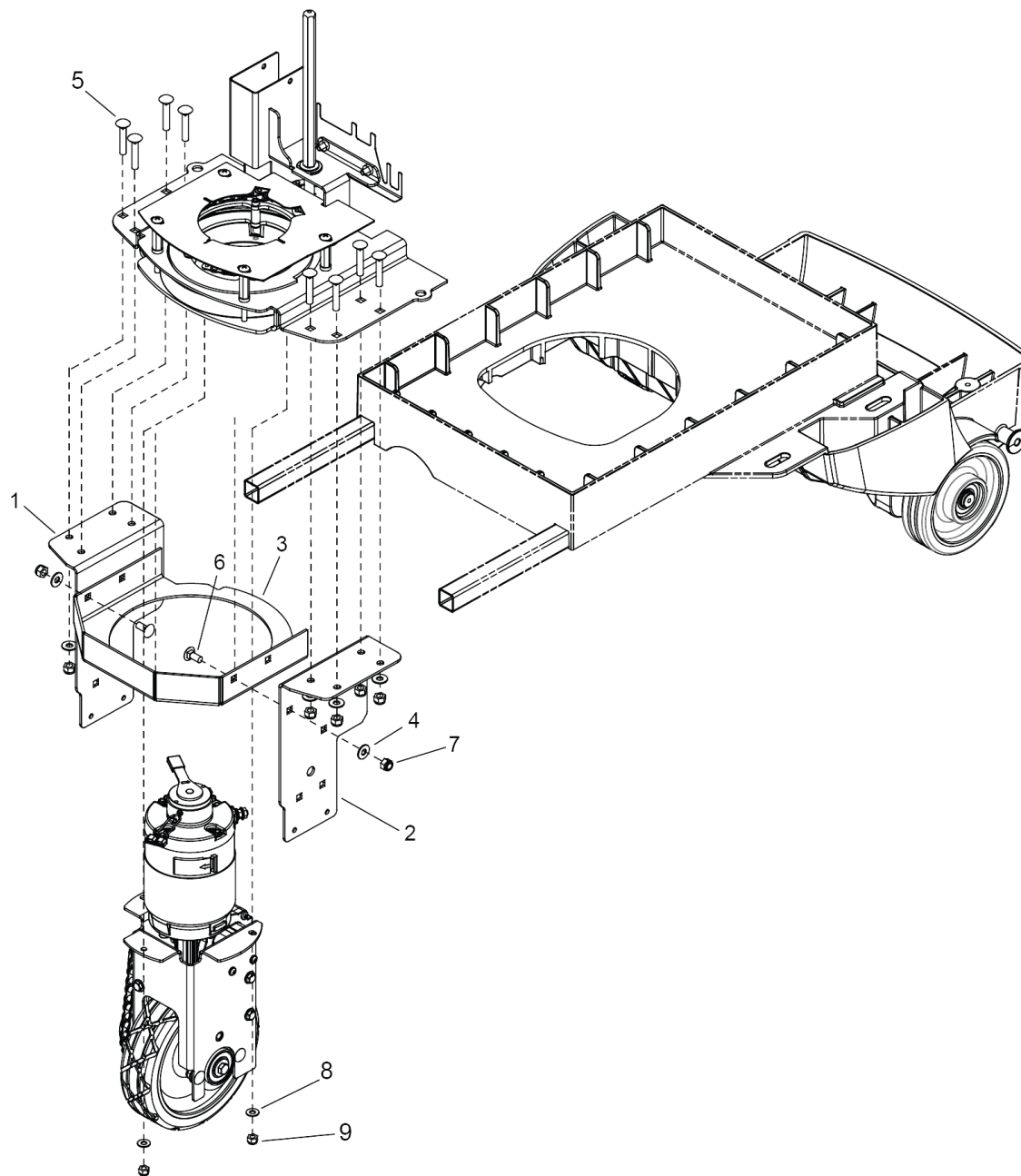

230 DRIVE MOUNTING - FROM SERIAL NUMBER (3\*) (0.250-418.0)

POS	Article no.	Description	Quantity	Unit
1	8.634-462.0	BRACKET, LINKAGE MOUNT	1.000	ST
2	8.631-973.0	BRACKET, LINKAGE MOUNT, LEFT	1.000	ST
3	8.640-541.0	BRACKET, C2 LOWER SUPPORT	1.000	ST
4	8.601-067.0	WASHER, 5/16 FLT SS	10.000	ST
5	8.627-669.0	SCREW, 5/16-18 X 1.75 CARR SS	8.000	ST
6	8.627-607.0	SCREW, 5/16-18 X .75 CARR SS	2.000	ST
7	8.627-083.0	NUT, 5/16-18 HEX NYLOCK SS	10.000	ST
8	8.601-063.0	WASHER, 1/4 SS	3.000	ST
9	8.600-581.0	NUT, 1/4-20 HEX NYLOCK SS	3.000	ST

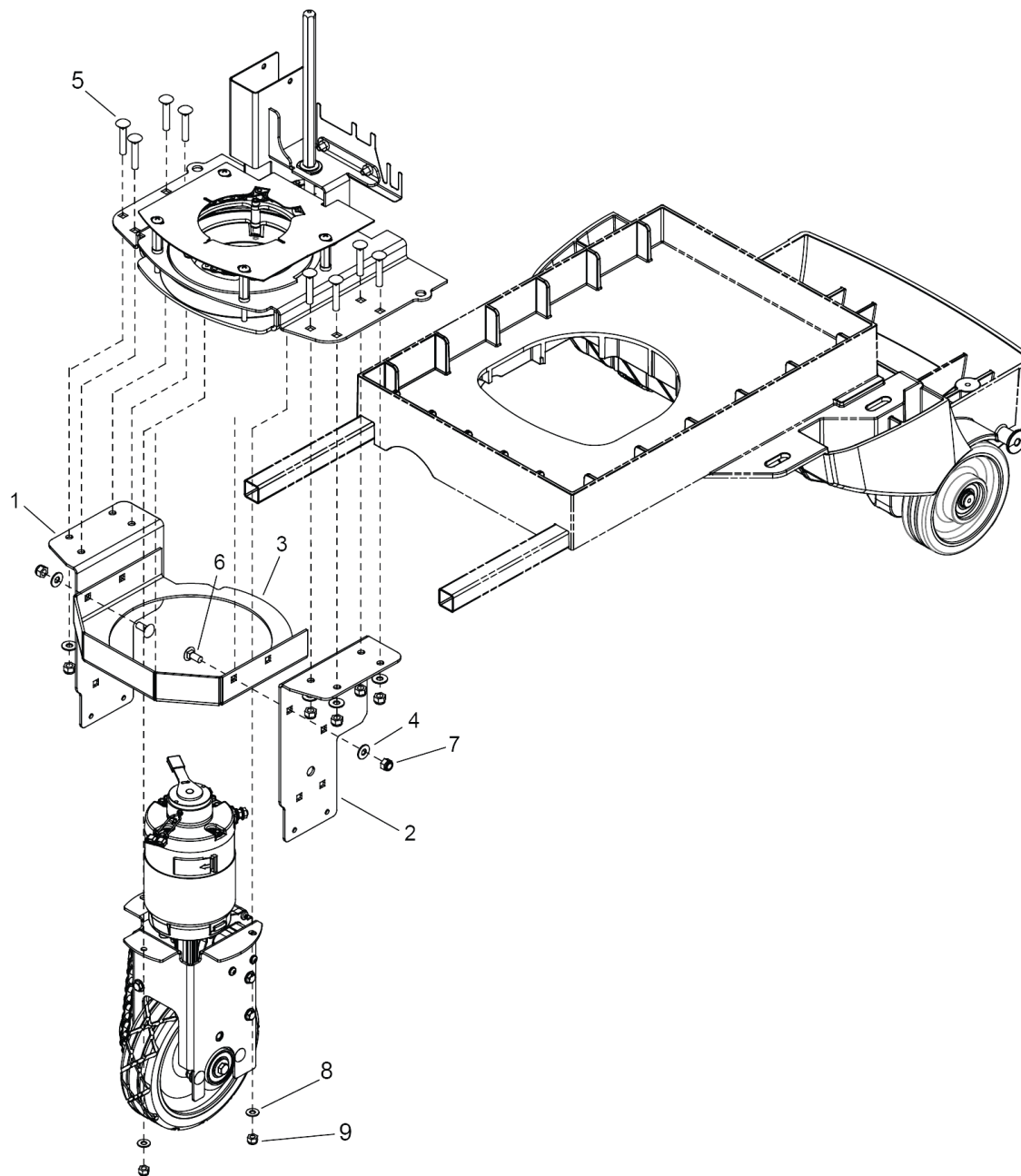

## 240 DRIVE MOUNTING - PRIOR TO SN (3\*) (0.250-419.0)

POS	Article no.	Description	Quantity	Unit
1	8.634-462.0	BRACKET, LINKAGE MOUNT	1.000	ST
2	8.631-973.0	BRACKET, LINKAGE MOUNT, LEFT	1.000	ST
3	8.633-163.0	BRACKET, ROLLER GUIDE	1.000	ST
4	8.601-067.0	WASHER, 5/16 FLT SS	12.000	ST
5	8.627-669.0	SCREW, 5/16-18 X 1.75 CARR SS	8.000	ST
6	8.627-607.0	SCREW, 5/16-18 X .75 CARR SS	2.000	ST
7	8.627-083.0	NUT, 5/16-18 HEX NYLOCK SS	12.000	ST
8	8.627-476.0	SCREW, 1/4-20 X .5 HHCS STL GR5 ZNPLT	1.000	ST
9	8.636-387.0	CLAMP, 5/8" OD CUSHIONED	1.000	ST
10	8.632-934.0	PLATE, CHAIN GUARD	1.000	ST
11	8.627-894.0	WASHER, 1/4 STL ZNPLT	1.000	ST

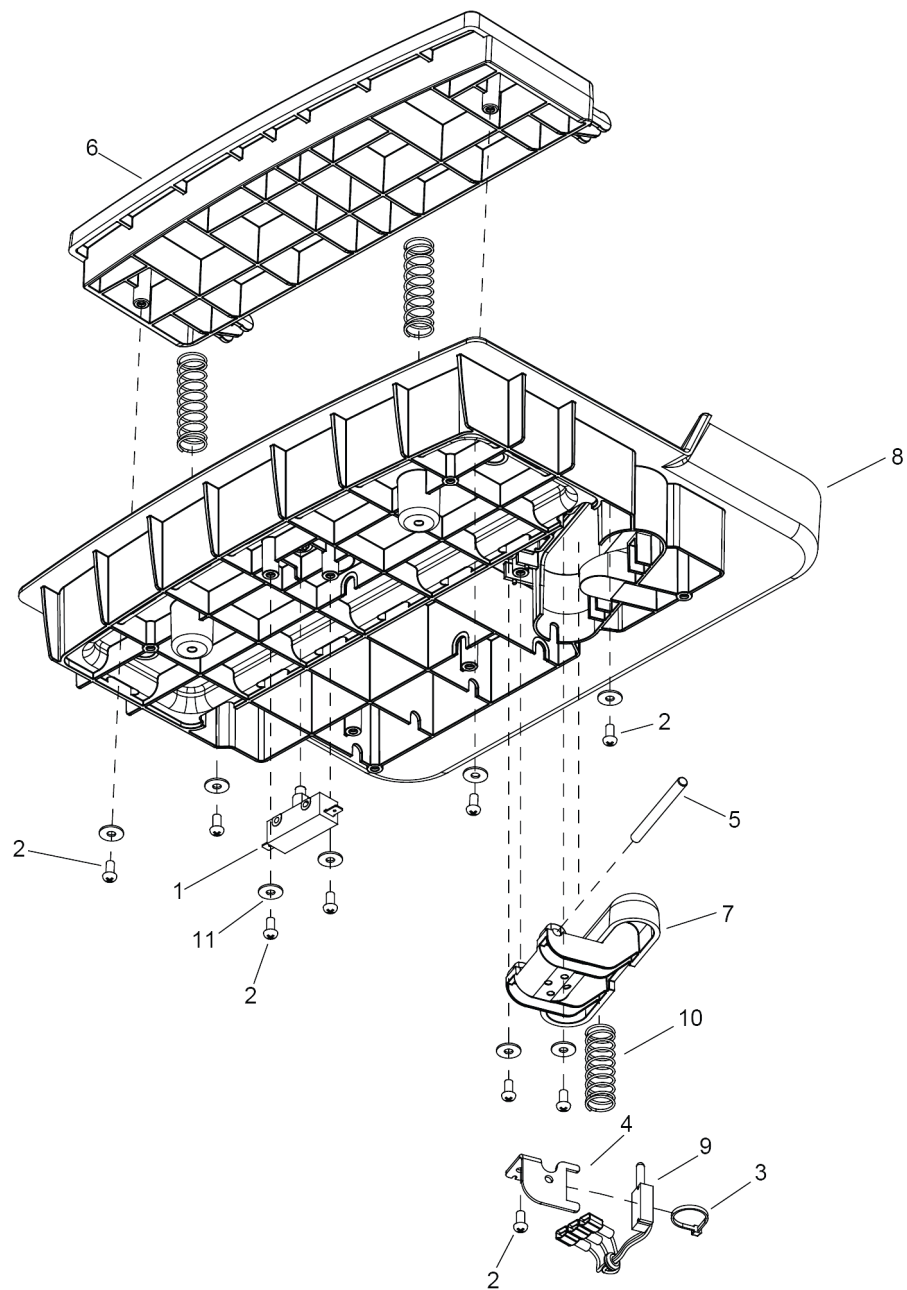

## 250 PEDAL PLATFORM (0.250-420.0)

POS	Article no.	Description	Quantity	Unit
1	8.600-711.0	Switch 25A SPST 125-250V SNAP	1.000	ST
2	8.617-298.0	SCREW, KA50 X 10 OVHCS STL WN1412 ZNPLT	9.000	ST
3	8.626-493.0	CABLE TIE, 3.5" UL/CSA	1.000	ST
4	8.632-615.0	BRKT, LINEAR POT	1.000	ST
5	8.632-614.0	PIN, DOWEL 1/4 X 2.75 STL	1.000	ST
6	8.633-424.0	PEDAL, HEEL, BLK	1.000	ST
7	8.633-469.0	PEDAL, ACCELERATOR, YEL	1.000	ST
8	8.633-423.0	PLATFORM, OPERATOR, BLK	1.000	ST
9	8.631-156.0	POTENTIOMETER ASM, LINEAR	1.000	ST
10	8.625-497.0	SPRING, COMP 18MMOD X 83 X 2	3.000	ST
11	8.617-333.0	WASHER, M5 SS ISO7093	8.000	ST

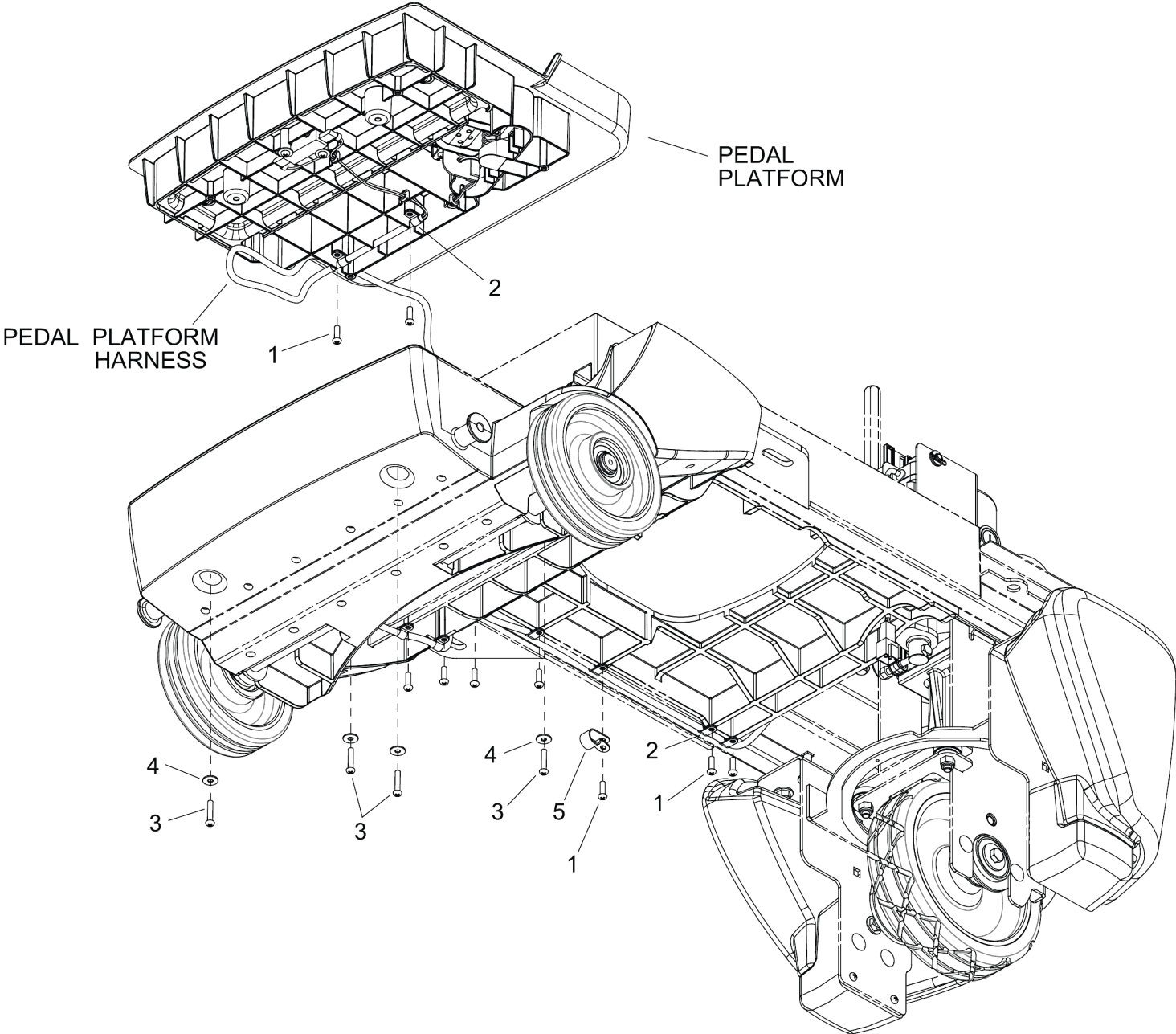



## 260 PEDAL PLATFORM MOUNTING (0.250-421.0)

---

<b>POS</b>	<b>Article no.</b>	<b>Description</b>	<b>Quantity</b>	<b>Unit</b>
1	7.303-104.0	Screw 5x16 -A2-70 (IN6RD)	9.000	ST
2	8.619-844.0	CLAMP, 1/4 PLASTIC CABLE	9.000	ST
3	8.632-791.0	SCREW, KA50 X 25 PTOVHS STL WN1412 ZNPLT	4.000	ST
4	8.617-333.0	WASHER, M5 SS ISO7093	4.000	ST
5	8.619-847.0	Clamp 9/16 DIA NYLON	1.000	ST

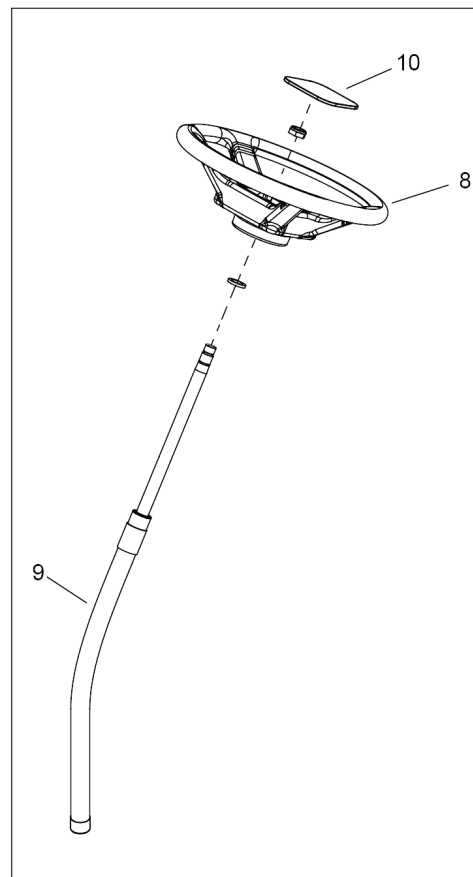
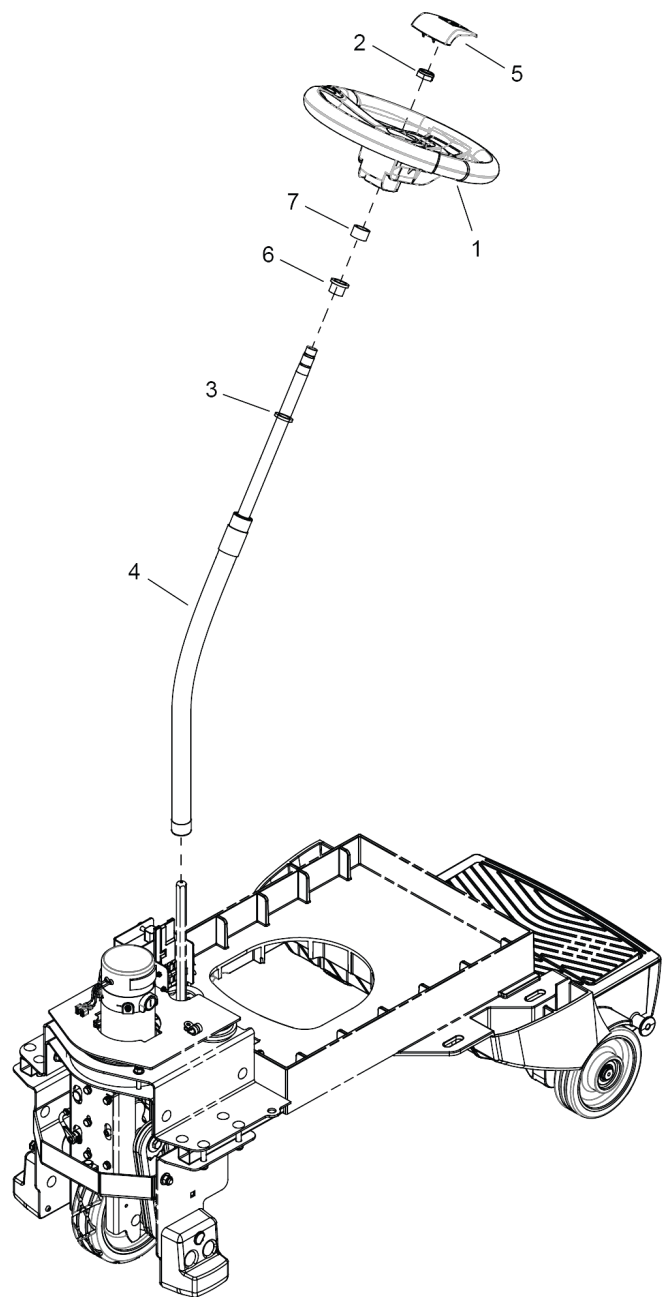

## 270 STEERING (0.250-461.0)

POS	Article no.	Description	Quantity	Unit
1	6.435-799.0	Steering wheel	1.000	ST
2	8.627-161.0	NUT, 5/8-18 HEXTHIN NYLOCK STL GR2 ZNPLT	1.000	ST
3	8.627-942.0	WASHER, .765 X 1.25 X .08 FLT NYL	1.000	ST
4	8.635-569.0	Steering shaft	1.000	ST
	<b>Item text1:</b> COMPLETE			
5	6.640-353.0	Cap steering wheel KÄRCHER	1.000	ST
6	8.622-879.0	BUSHING, .753 X .875 X .75 FLG	2.000	ST
7	8.633-395.0	BUSHING, .751 D X 1 X .625 FLG	1.000	ST
8	8.625-961.0	Wheel STEERING 40 SPLINE HUB	1.000	ST
9	8.637-837.0	ASM, SHAFT, STEERING, CHARIOT 2	1.000	ST
10	8.623-481.0	COVER, STEERING WHEEL	1.000	ST

## 280 VACUUM - OPTIONAL (0.250-462.0)

POS	Article no.	Description	Quantity	Unit
1	8.627-392.0	SCREW, 1/4-20 X 1.75 PHPNHMS SS	3.000	ST
2	8.601-063.0	WASHER, 1/4 SS	3.000	ST
3	8.635-329.0	BRACKET, MOUNTING, VAC MOTOR	1.000	ST
4	8.631-292.0	GASKET, VAC MOTOR	1.000	ST
5	6.490-197.3	Turbine 2-level 36V 650W (CCL)	1.000	ST
6	8.626-494.0	Cable tie 11.38" UL/CSA	1.000	ST
7	8.632-750.0	BUSHING, .250 X .75 X 1 MOUNT VIBRATION	3.000	ST
8	8.600-240.0	Clamp 2.0" WORM GEAR X .312W	1.000	ST
9	8.632-033.0	HOSE ASM, 1.5 BLK VAC X12	1.000	ST
10	8.635-615.0	HOSE, 1.5" X 7.75", 4:1 STRETCH	1.000	ST
11	8.629-122.0	SCREW, KA40 X 16 FLT SS WN1413	2.000	ST
12	8.635-591.0	CLIP, 1-3/4", PLASTIC	1.000	ST
13	8.614-333.0	MOTOR FILTER U19836	1.000	ST
14	8.635-465.0	FRAME, FILTER	1.000	ST
15	8.627-764.0	SCREW, 1/4-20 X .75 PHTRHMS SS	2.000	ST

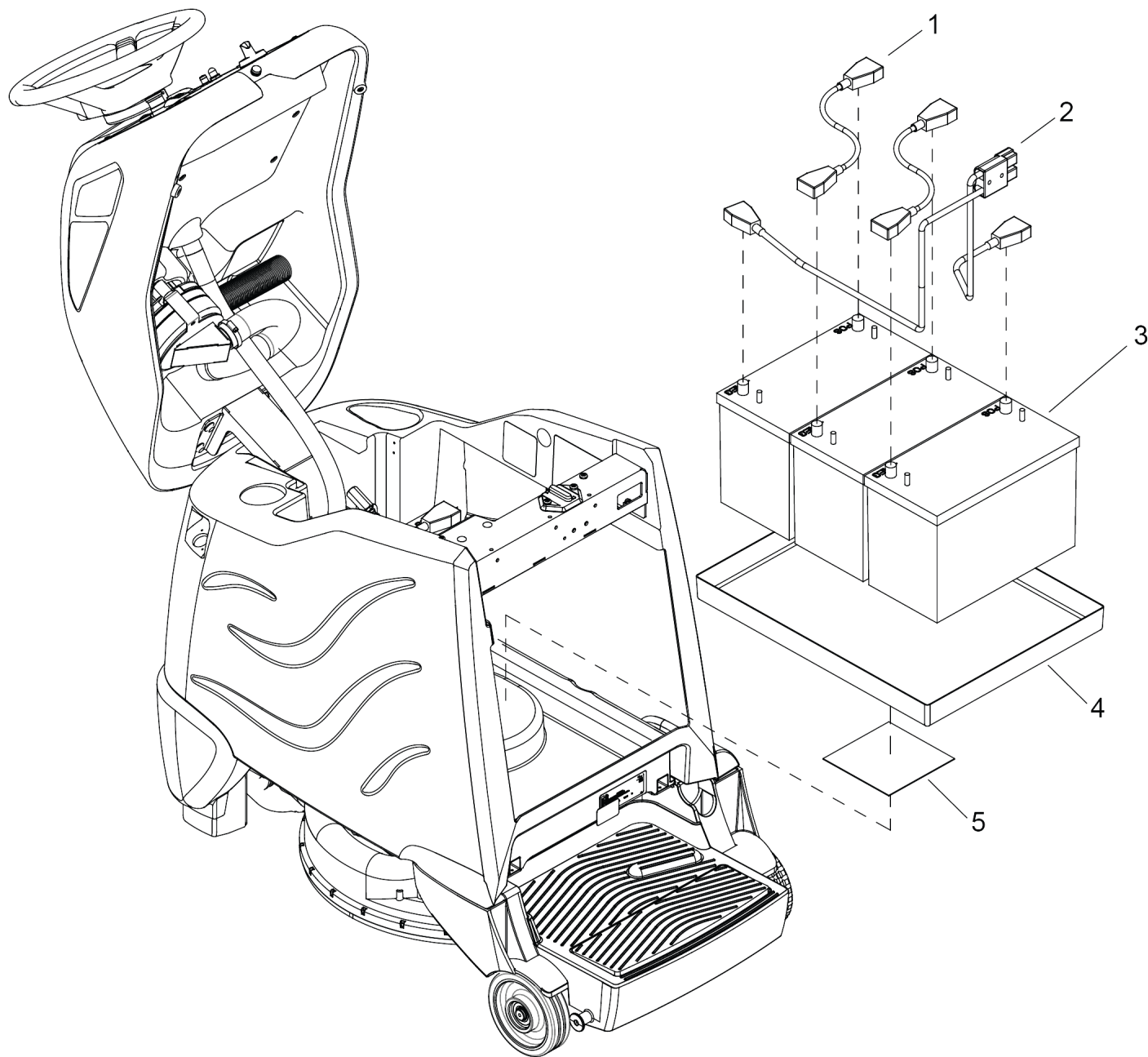

## 290 WIRING - BATTERY (0.250-463.0)

POS	Article no.	Description	Quantity	Unit
1	8.632-972.0	BATT, CBL, ASM, JUMPER	2.000	ST
2	8.635-612.0	CABLE, ASM, BATTERY	1.000	ST
3	8.628-341.0	BATTERY, 12V, 225AH (J185H-AC)	3.000	ST
		<b>Item text1:</b> NOT SHOWN		
3	8.632-863.0	BATTERY, 12V 114A/H AGM	3.000	ST
		<b>Item text1:</b> NOT SHOWN		
3	8.622-843.0	BATTERY, 12V AGM 234AH	3.000	ST
		<b>Item text1:</b> NOT SHOWN		
3	8.622-840.0	BATTERY, 12V, 130AH (30XHS)	3.000	ST
4	8.639-531.0	Tub battery	1.000	ST
		<b>Item text1:</b> REQD. WITH 86283410 & 86228430		
5	8.635-955.0	TAPE, 1/16" T X 6.0" SQ. 2 SIDE ADH	1.000	ST

**Serial Numbers**

REF. NO.	MODEL: SERIAL #
1	10020310000177, 10020320000095, 10020330000083, 10020340000053, 10020350000188, 10020360100300
2	10020310000181, 10020320000100, 10020330000092, 10020340000056, 10020350000196, 10020360100317
3	10020310000235, 10020320000158, 10020330000114, 10020340000082, 10020350000220, 10020360100357
4	10020310000244, 10020320000158, 10020330000114, 10020340000085, 10020350000227, 10020360100360
5	10020310000280, 10020320000163, 10020330000137, 10020340000112, 10020350000271, 10020360100459, 10020370000182, 10020410000047, 10020420000001
6	10020310000349, 10020320000253, 10020330000148, 10020340000130, 10020350000337, 10020360100557
7	10020310000369, 10020320000275, 10020330000153, 10020340000144, 10020350000358, 10020360100591

9020 Chariot iGloss 20 Serial Numbers (0.250-921.0)

---

<b>POS</b>	<b>Article no.</b>	<b>Description</b>	<b>Quantity</b>	<b>Unit</b>
10	0.250-480.0	SERIAL NUMBER PAGE	1.000	ST

---



X7	BRAKE Y1		1 - 15/RT 2 - 14/SW
X8	POT PLATFORM U2		1 - 19/BN 2 - 20/WS 3 - 18/OR 4 - 17/GN 5 - 16/BL 6 - NC
X9	TRACTION M3		1 - 21/RT 2 - 22/SW
X10	BRUSH SHUNT M1		1 - 1/WS 2 - 2/SW 3 - 7/RT 4 - 13/GN
X11	ACTUATOR M4		1 - 3/RT 2 - 4/WS
X13	VACUUM M2		1 - 23/WS 2 - 24/SW
U1	INTERLOCK S5		1 - 11/SW 2 - 12/RT
X3	HORN H3	PANEL TB	5 - 5/WS 6 - 6/SW
X6	CHARGER OPTION		1 - 11C/SW 2 - 12C/RT

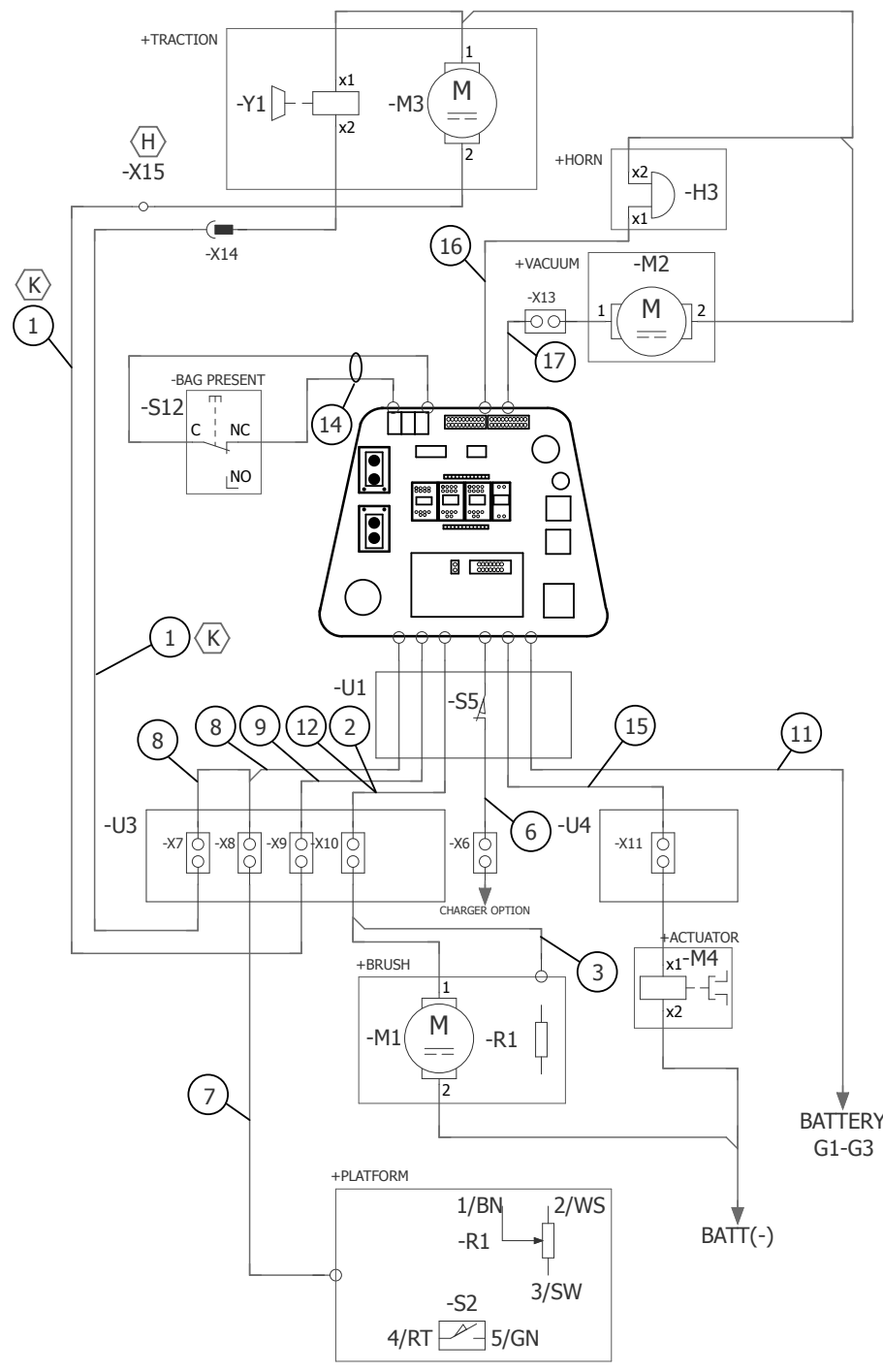

Aderfarben	Wire color
rot/rt	red
schwarz/sw	black
weiB/ws	white
braun/bn	brown
blau/bl	blue
gelb/ge	yellow
orange/or	orange
grau/gr	gray
grün/gn	green
violett/vi	violet
rosa/rs	pink

REV	DESCRIPTION	ECN	BY	DATE
A	RELEASE FOR PRODUCTION	-	-	-
B	CORRECT DIODE POSITION AND WIRING	1110050742	PK	10-10-11
C	ADD WIRE #57, 58 AND DIODE TO DRAWING	1111170640	SG	10-17-11
D	OMIT #56, ROUTE #8 TO HOUR METER OMIT 86354350 AND 86354360 REPLACE WITH 86359290 AND 86359300	1111300635	SG	10-30-11
E	MOVE #53 FROM X3-7 TO X1-10	1202080830	PK	02-08-12
F	ADD BRAKE HARNESS 86362990	1203140823	PK	03-12-12
G	#70 WAS #69, #69 WAS #18, #70 WAS #69, #69 WAS #18,	1210151048	VV	10-26-12
H	ADD TRACTION HARNESS 86365410	1208150555	VV	11-08-12
J	86412050 WAS 86365410, 86412060 WAS 86362990	5026112	RJC	03-14-16
K	86429930 WAS 86412050 & 86412060	3032283	JA	03-07-19

17	86333140	HARNESS, CS20 MAIN VACUUM	1	OPTION
16	86333170	HARNESS, CS20 MAIN HORN	1	PART OF 86356100
15	86344450	HARNESS, MAIN ACTUATOR	1	PART OF 86356100
14	86354370	HARNESS, IGLOSS20 BAG PRESENT	1	PART OF 86356100
13	86354380	HARNESS, ROTARY SWITCH	1	
12	86354390	HARNESS, IGLOSS20 BRUSH	1	PART OF 86356100
11	86354400	HARNESS, IGLOSS20 MAIN POWER	1	PART OF 86356100
10	86354410	HARNESS, PANEL IGLOSS20	1	KNA VERSION
9	86356340	HARNESS, IGLOSS20 MAIN TRACTION	1	PART OF 86356100
8	86356350	HARNESS, IGLOSS20 MAIN POT AND BRAKE	1	PART OF 86356100
7	86356360	HARNESS, IGLOSS20 OPERATOR PLATFORM	1	
6	86356370	HARNESS, IGLOSS20 MAIN CHARGER	1	PART OF 86356100
5	86359190	HARNESS, SHUNT JUMPER WIRE, BRAIDED	1	PART OF 86356100
4	86359200	HARNESS, SHUNT JUMPER WIRE	1	PART OF 86356100
3	86359290	HARNESS, IGLOSS20 CURRENT SHUNT JUMPER	1	PART OF 86356100
2	86359300	HARNESS, IGLOSS20 SHUNT SENSE	1	PART OF 86356100
1	86429930	Cable set lower traction	1	

REF	PART NO	DESCRIPTION	QTY	REMARKS
<p>PROPRIETARY &amp; CONFIDENTIAL - THE INFORMATION CONTAINED IN THIS DRAWING IS THE PROPERTY OF KÄRCHER. IT IS TO BE USED ONLY FOR THE PROJECT AND NOT BE REPRODUCED OR TRANSMITTED IN ANY FORM OR BY ANY MEANS, ELECTRONIC OR MECHANICAL, WITHOUT THE WRITTEN PERMISSION OF KÄRCHER. THIS DRAWING IS PROTECTED BY THE COPYRIGHT LAWS OF THE UNITED STATES.</p>				
TOLERANCES UNLESS OTHERWISE NOTED:		<p>GRP, HARNESS ASM, IGLOSS20</p>		
<p>BOTH MILLIMETERS X &amp; 0.1 X &amp; 0.2 X &amp; 0.5 X &amp; 0.015</p>		<p>DATE: 08-23-11</p>		
<p>SCALE: NONE</p>		<p>DRAWING NUMBER: 86354930</p>		
<p>DRAWING IS APPROVED BY ELECTRONIC SIGNATURE IN THIS SYSTEM</p>		<p>1 OF 10</p>		

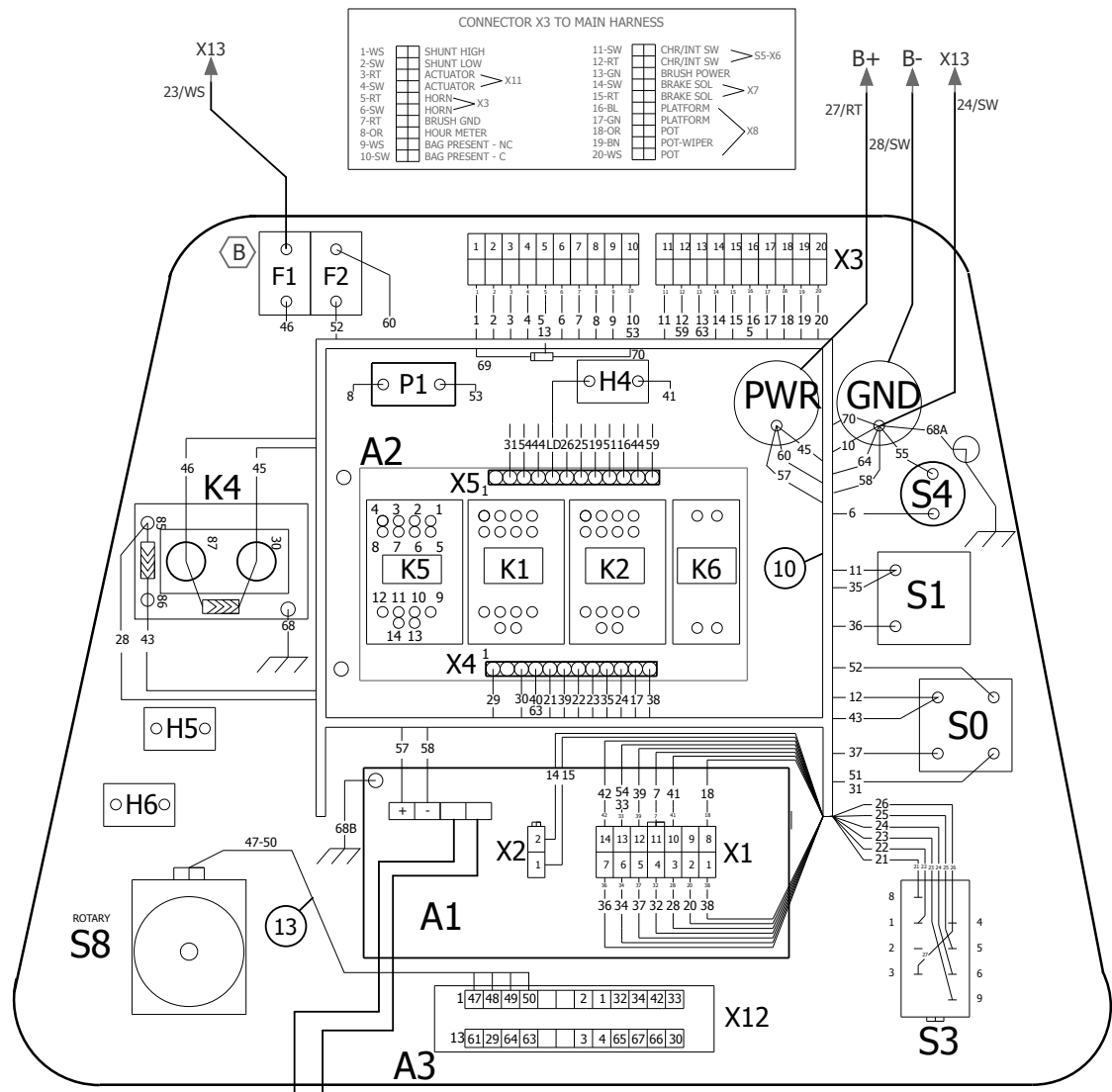

CONNECTOR X3 TO MAIN HARNESS

1-WS	SHUNT HIGH	11-SW	CHR/INT SW	> S5-X6
2-SW	SHUNT LOW	12-RT	CHR/INT SW	
3-RT	ACTUATOR	13-GN	BRUSH POWER	> X7
4-SW	ACTUATOR	14-SW	BRAKE SOL	
5-RT	HORN	15-RT	BRAKE SOL	> X8
6-SW	HORN	16-BL	PLATFORM	
7-RT	BRUSH GND	17-GN	PLATFORM	
8-OR	HOUR METER	18-OR	POT	
9-WS	BAG PRESENT - NC	19-BN	POT-WIPER	
10-SW	BAG PRESENT - C	20-WS	POT	

47-WS	ROTARY INPUT	61-SW	+5V
48-GE	ROTARY INPUT	29-SW	RELAY GROUND
49-GN	ROTARY INPUT	64-SW	BATTERY GND
50-BN	ROTARY INPUT	63-RT	BATTERY POS
	OPEN		OPEN
	OPEN		OPEN
2-SW	SHUNT LOW	3-WS	ACTUATOR
1-SW	SHUNT HIGH	4-SW	ACTUATOR
52-GR	SLOW/FAST INH	65-SW	LED POWER
34-OR	INHIBIT 1	67-GN	LED GRN
42-SW	INHIBIT 2	66-RT	LED RED
33-SW	CONTROL LOW	30-RT	H-BRIDGE INPUT

Aderfarben	Wire color
rot/rt	red
schwarz/sw	black
weiB/ws	white
braun/bn	brown
blau/bl	blue
gelb/ge	yellow
orange/or	orange
grau/gr	gray
grün/gn	green
vioplett/vi	violet
rosa/rs	pink

INSPECTION DIMENSION CRITICAL TO QUALITY

PROPRIETARY & CONFIDENTIAL. THE INFORMATION CONTAINED IN THIS DRAWING IS THE EXCLUSIVE PROPERTY OF KÄRCHER NORTH AMERICA. THIS DRAWING IS PROTECTED BY THE COPYRIGHT LAWS OF THE UNITED STATES.

**KÄRCHER**

TOLERANCES: UNLESS OTHERWISE NOTED

INCH	MILLIMETERS
.XX ± 0.1	.X ± 0.2
.XXX ± 0.01	.XX ± 0.05
.XXX ± 0.015	.XXX ± 0.25

DATE: 06-23-11

DRAWING NUMBER: 86354930

DATE: 06-23-11

2 OF 10

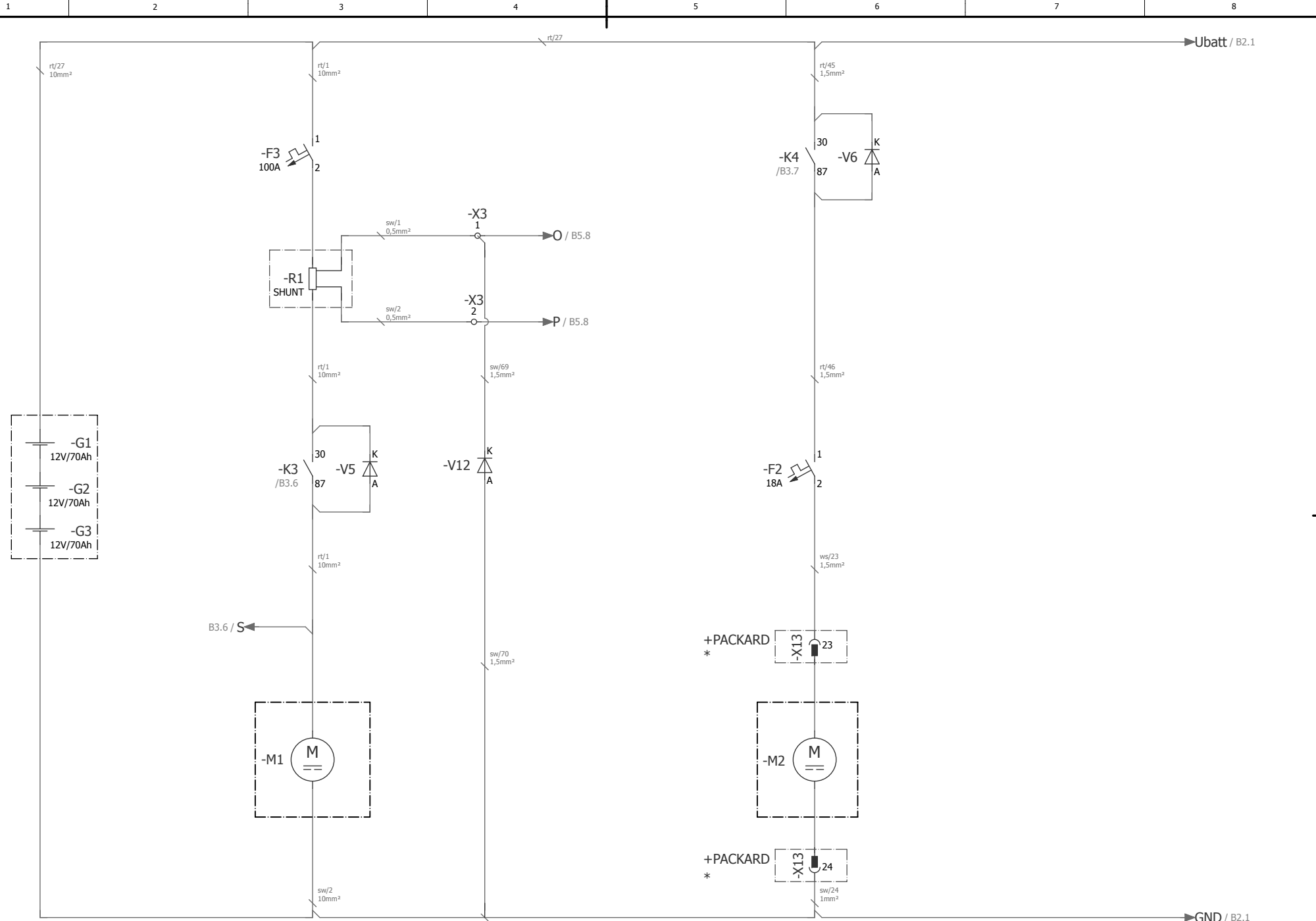

<b>KÄRCHER</b>		Material-Nr. / material no.	Benennung / description GRP, HARNESS ASM, IGLOSS20			Datei / file 86354930		sheet B1	of 10
Anlage plant	Ort location	Auftrag order	Blattbenennung / sheet description STROMLAUFPLAN/CIRCUIT DIAGRAM			Datum date	Gezeichnet drawn by	Gepueft checked by	Normgeprueft std. checked by
=BR	+ER					8.30.11			

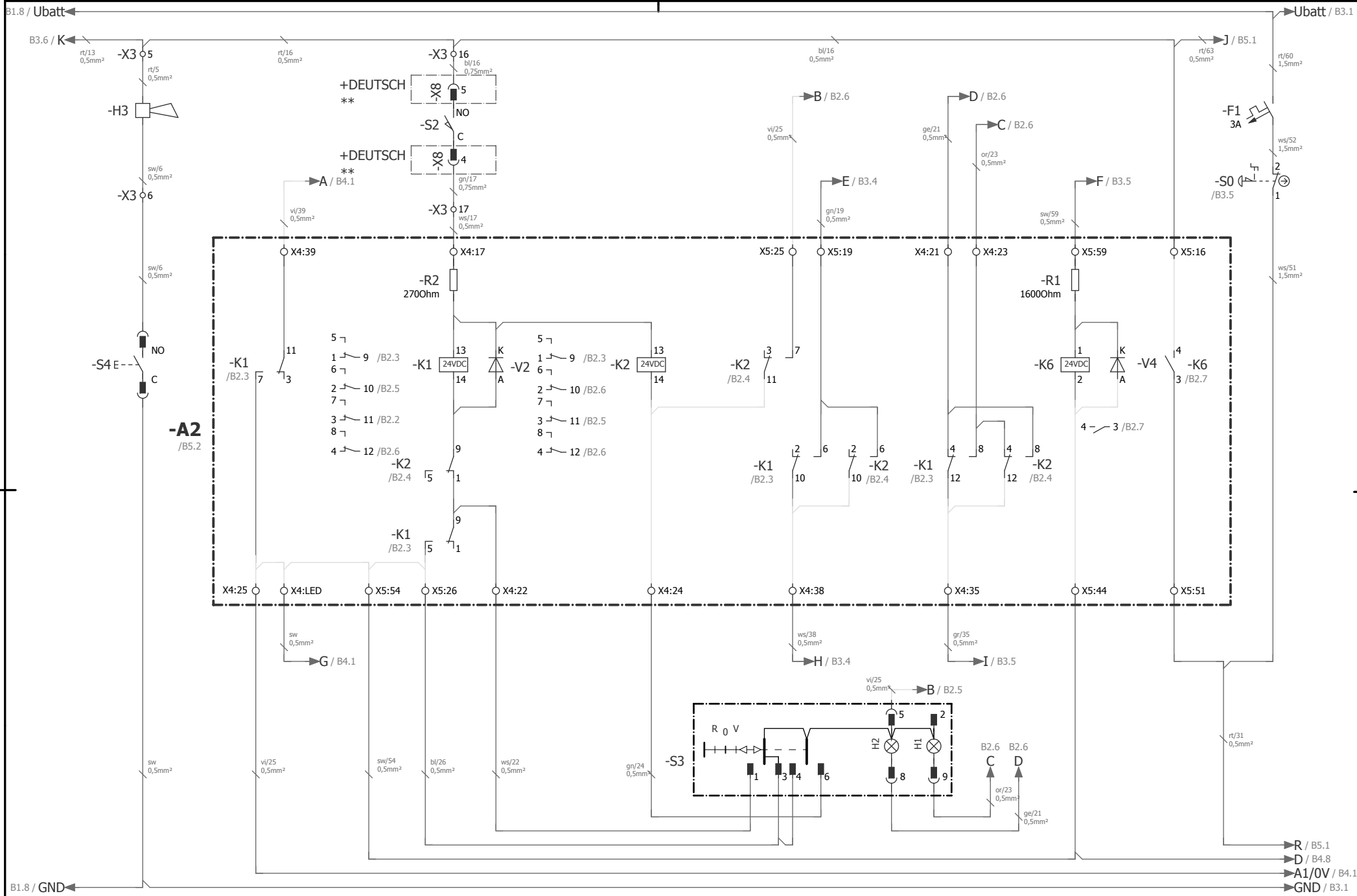

<b>KÄRCHER</b>		Material-Nr. / material no.	Benennung /description GRP, HARNESS ASM, IGLOSS20	Datei / file 86354930	sheet B2	of 10
Anlage plant =BR	Ort location +ER	Auftrag order	Blattbenennung / sheet description STROMLAUFPLAN/CIRCUIT DIAGRAM	Datum date 8.30.11	Gezeichnet drawn by	Gepüeft checked by
				Normgeprüft std. checked by		



-A1  
/B3.1

**i-DRIVE  
i 36-70  
36VDC / 70A**

SLOW/FAST SWITCH

INHIBIT 1

REVERSE SWITCH

STATUS INDICATOR

-X1  
/B3.3

INHIBIT 2

-X2  
/B3.2

0V



gr/32  
0,5mm<sup>2</sup>

gr/34  
0,5mm<sup>2</sup>

vi/39  
0,5mm<sup>2</sup>

ws/41  
0,35mm<sup>2</sup>

sw/42  
0,5mm<sup>2</sup>

sw/54  
0,75mm<sup>2</sup>

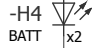

sw  
0,3mm<sup>2</sup>

B5.8 / L ←

B5.8 / M ←

B2.2 / A ←

B2.2 / G ←

B5.8 / N ←

B2.8 / A1/0V ←

B3.8 / GND ←

→ D / B2.8

→ GND / B5.1



Material-Nr. / material no.

Benennung / description  
GRP, HARNESS ASM, IGLOSS20

Datei / file  
86354930

sheet of  
B4 10

Anlage plant  
=BR

Ort location  
+ER

Auftrag order  
Blattbenennung / sheet description  
STROMLAUFPLAN/CIRCUIT DIAGRAM

Datum date  
8.30.11

Gezeichnet drawn by

Gepueft checked by

Normgeprüft std. checked by

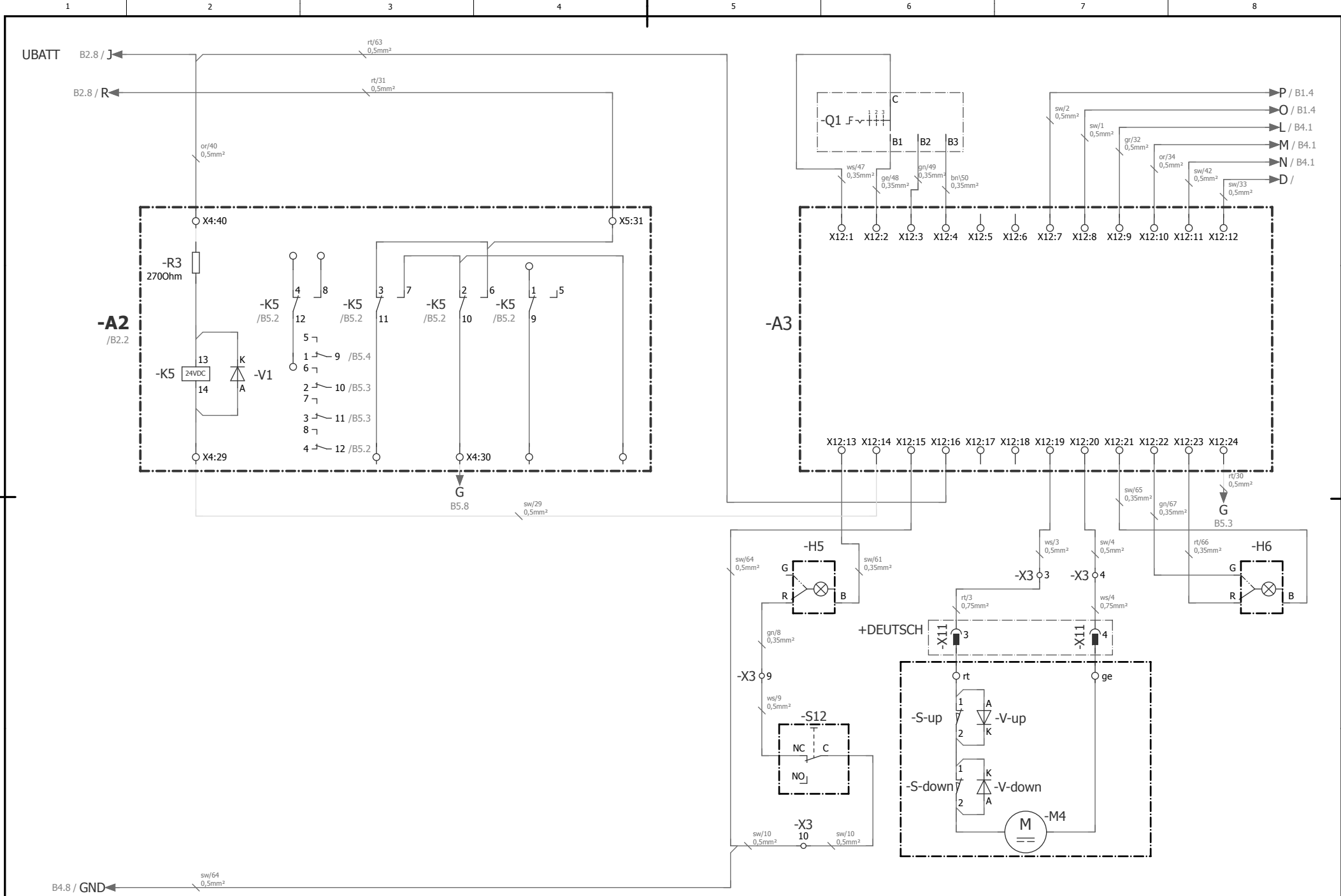

		Material-Nr. / material no.	Benennung / description GRP, HARNESS ASM, IGLOSS20	Datei / file 86354930	sheet B5	of 10
Anlage plant =BR	Ort location +ER	Auftrag order	Blattbenennung / sheet description STROMLAUFPLAN/CIRCUIT DIAGRAM	Datum date 8.30.11	Gezeichnet drawn by	Gepueft checked by
				Normgeprueft std. checked by		

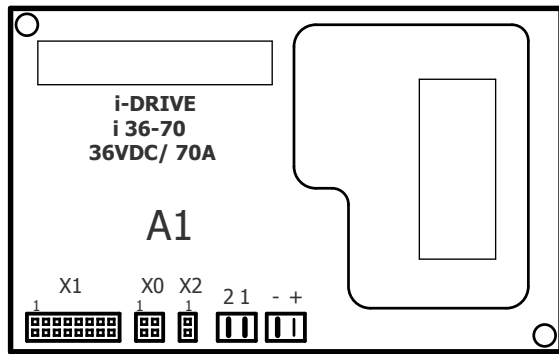

Aderfarben	Wire color
rot/rt	red
schwarz/sw	black
weiß/ws	white
braun/bn	brown
blau/bl	blue
gelb/ge	yellow
orange/or	orange
grau/gr	gray
grün/gn	green
violett/vi	violet
rosa/rs	pink

FRONT

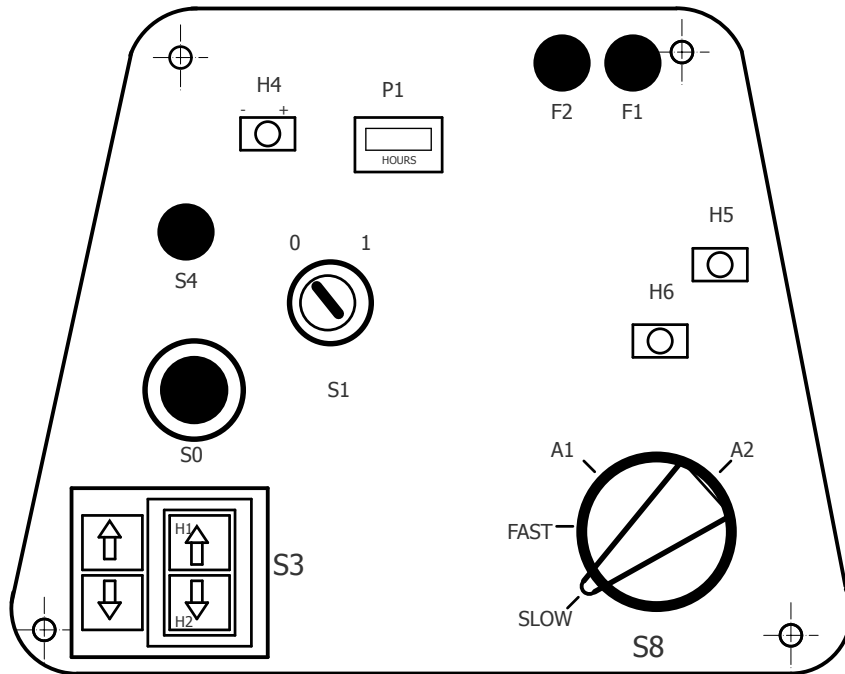

BACK

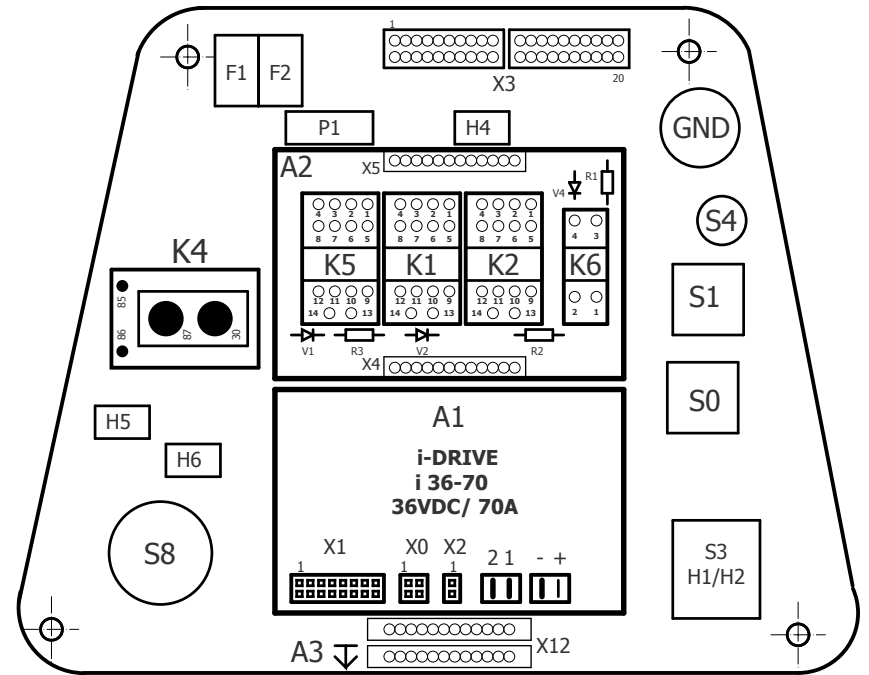

**KÄRCHER**

Material-Nr. / material no.

Benennung / description  
GRP, HARNESS ASM, IGLOSS20

Datei / file  
86354930

sheet of  
B6 10

Anlage plant  
=BR

Ort location  
+ER

Auftrag order  
Blattbenennung / sheet description  
AUFBAU/CONSTRUCTION

Datum date  
8.30.11

Gezeichnet drawn by

Gepüeft checked by

Normgeprüft std. checked by



**D**

**GB**

A1 FAHRSTEUERUNG  
 A2 RELAISPLATINE  
 A3 PROCESSOR  
  
 F1 SICHERUNGSAUTOMAT-SAUGTURBINE  
 F2 SICHERUNGSAUTOMAT-FAHRSTEUERUNG  
  
 G1-G3 BATTERIE 12V/ 70Ah  
  
 H1 MELDELAMPE-FAHRTRICHTUNG-RÜCKW.  
 H2 MELDELAMPE-FAHRTRICHTUNG-VORW.  
 H3 HUPE  
 H4 LED-BATT.  
 H5 LED  
 H6 LED  
  
 K1 RELAIS-FAHRTRICHTUNG RÜCKW.  
 K2 RELAIS-FAHRTRICHTUNG VORW.  
 K3 RELAIS-BÜRSTENMOTOR  
 K4 RELAIS-SAUGTURBINE  
 K5 RELAIS-HUBMOTOR  
 K6 HAUPTRELAIS  
  
 M1 BÜRSTENMOTOR  
 M2 MOTOR-SAUGTURBINE  
 M3 FAHRMOTOR  
 M4 HUBMOTOR / BÜRSTENKOPF / SAUGLEISTE  
  
 S0 NOT-AUS  
 S1 SCHLÜSSELSCHALTER  
 S2 MICROSCHALTER-PLATTFORM  
 S3 TASTER-VORW/RÜCKW.  
 S4 TASTER-HUPE  
 S5 MICROSCHALTER-HAUBE  
 S8 PROGRAMMSCHALTER  
 S11 CHARGER  
 S12 BAG PRESENT  
  
 R1 SHUNT  
  
  
 P1 BETRIEBSSTUNDENZÄHLER  
  
 V1/V2/V4/V4/V5/V6/V7/V8/V9/V10/V11/V12 DIODE  
 V-UP & V-DOWN DIODE-MOTOR M4  
 X3 KLEMMLEISTE  
 X12 KLEMMLEISTE  
 \*\*X6/X7/X8/X11 - DEUTSCH CONNECTOR  
 \*X9/X10/X13 - PACKARD CONNECTOR  
 X14 - FASTON TERMINALS  
 X15 - RING TERMINALS  
  
 Y1 MAGNETBREMSE

A1 DRIVE CONTROL  
 A2 RELAY BOARD  
 A3 PROCESSOR  
  
 F1 CIRCUIT BREAKER-VACUUM MOTOR  
 F2 CIRCUIT BREAKER-DRIVE CONTROL  
  
 G1-G3 BATTERY 12V/ 70Ah  
  
 H1 SIGNAL LAMPS REVERSE DIRECTION  
 H2 SIGNAL LAMPS DIRECTION FORWARD  
 H3 HORN  
 H4 LED-BATT.  
 H5 LED  
 H6 LED  
  
 K1 RELAYS-REVERSE DIRECTION  
 K2 RELAYS DIRECTION FORWARD  
 K3 RELAYS BRUSH MOTOR  
 K4 RELAYS VACUUM MOTOR  
 K5 RELAYS ACTUATOR  
 K6 RELAYS MAIN  
  
 M1 BRUSH MOTOR  
 M2 VACUUM MOTOR  
 M3 TRACTION MOTOR  
 M4 LINEAR ACTUATOR MOTOR BRUSH / SQUEGEE  
  
 S0 EMERGENCY SWITCH  
 S1 KEYSWITCH  
 S2 MICROSWITCH-PLATFORM  
 S3 BUTTON REVERSE FORWARD  
 S4 HORN BUTTON  
 S5 MICROSWITCH-COVER  
 S8 PROGRAMSWITCH  
 S11 CHARGER  
 S12 BAG PRESENT  
  
 R1 SHUNT  
  
  
 P1 HOURS METER  
  
 V1/V2/V3/V4/V5/V6/V7/V8/V9/V10/V11/V12 DIODE  
 V-UP & V-DOWN DIODE-MOTOR M4  
 X3 TERMINAL BLOCK  
 X12 TERMINAL BLOCK  
 \*\*X6/X7/X8/X11 - DEUTSCH CONNECTOR  
 \*X9/X10/X13 - PACKARD CONNECTOR  
 X14 - FASTON TERMINALS  
 X15 - RING TERMINALS  
  
 Y1 BRAKE

 <b>KÄRCHER</b>		Material-Nr. / material no.		Benennung /description GRP, HARNESS ASM, IGLOSS20			Datei / file 86354930		sheet	of
Anlage plant	Ort location	Auftrag order	Blattbenennung / sheet description LEGENDE/LEGEND			Datum date	Gezeichnet drawn by	Gepüeft checked by	Normgeprüft std. checked by	
=BR	+ER					8.30.11				

**F**

**E**

A1 CABEZAL  
 A2 RELAIS du CONSEIL  
 A3 PROCESSOR

F1 DISJONCTEUR - VIDE  
 F2 DISJONCTEUR - DRIVE

G1-G3 BATTERIE 12V/ 70Ah

H1 LAMPES DE SIGNALISATION DEMI-TOUR  
 H2 LAMPES DE SIGNALISATION VERS L'AVANT  
 H3 HORN  
 H4 LED-BATTERIE  
 H5 LED  
 H6 LED

K1 RELAIS-REVERSE  
 K2 RELAIS-FORWARD  
 K3 RELAIS-BROSSE  
 K4 RELAIS-VIDE  
 K5 RELAIS-ACTIONNEUR  
 K6 RELAIS-MAIN

M1 BROSSE DE MOTEUR  
 M2 VIDE MOTEUR  
 M3 MOTEUR DE TRACTION  
 M4 ACTIONNEUR A MOTEUR

S0 INTERRUPTEUR D'URGENCE  
 S1 INTERRUPTEUR A CLE  
 S2 MICRORUPTEUR PLATE-FORME  
 S3 INVERSEUR FORWARD  
 S4 HORN BOUTON  
 S5 MICRORUPTEUR COUVERTURE  
 S8 PROGRAMME SWITCH  
 S11 CHARGEUR  
 S12 BAG PRESENT

R1 SHUNT

P1 COMPTEUR D'HEURES

V1/V2/V4/V4/V5/V6/V7/V8/V9/V10/V11/V12 DIODE  
 V-UP & V-DOWN DIODE-MOTEUR M4

X3 BORNIER  
 X12 BORNIER  
 \*\*X6/X7/X8/X11 - DEUTSCH CONNECTOR  
 \*X9/X10/X13 - PACKARD CONNECTOR  
 X14 - FASTON TERMINALS  
 X15 - RING TERMINALS

Y1 BRAKE

A1 UNIDAD DE CONTROL  
 A2 JUNTA DE RELE  
 A3 PROCESSOR

F1 CORTACIRCUITOS - ASPIRADORA  
 F2 CORTACIRCUITOS - CONTROL DRIVE

G1-G3 BATERIA 12V/ 70Ah

H1 LAMPARAS DE DIRECCION - FRENTE  
 H2 LAMPARAS DE DIRECCION - REVERSA  
 H3 PITO  
 H4 LED- ACIDO DE BATERIA  
 H5 LED  
 H6 LED

K1 RELES REVERSA  
 K2 RELES FRENTE  
 K3 RELES SEPILLO DE MOTOR  
 K4 RELES MOTOR DE ASPIRADORA  
 K5 RELES ACTUADOR MOTOR  
 K6 RELE PRINCIPAL

M1 SEPILLO DE MOTOR  
 M2 MOTOR DE ASPIRADORA  
 M3 DE MOTORES DE TRACCION  
 M4 ACTUADOR MOTOR

S0 INTERRUPTOR DE EMERGENCIA  
 S1 LLAVE DE CONTACTO  
 S2 MICROINTERRUPTOR - PLATAFORMA  
 S3 BOTON REVERSE/FORWARD  
 S4 INTERRUPTOR DEL CLAXON  
 S5 MICROINTERRUPTOR - RECUBRIR  
 S8 PROGRAMA INTERRUPTOR  
 S11 CARGADOR  
 S12 BAG PRESENT

R1 SHUNT

P1 MEDIDOR DE HORAS

V1/V2/V3/V4/V5/V6/V7/V8/V9/V10/V11/V12 DIODE  
 V-UP & V-DOWN DIODE-MOTOR M4

X3 BLOQUE DE TERMINALES  
 X12 BLOQUE DE TERMINALES  
 \*\*X6/X7/X8/X11 - DEUTSCH CONNECTOR  
 \*X9/X10/X13 - PACKARD CONNECTOR  
 X14 - FASTON TERMINALS  
 X15 - RING TERMINALS

Y1 FRENO

		Material-Nr. / material no.		Benennung /description GRP, HARNESS ASM, IGLOSS20			Datei / file 86354930		sheet	of	
Anlage plant	Ort location	Auftrag order	Blattbenennung / sheet description LEGENDE/LEGEND			Datum date	Gezeichnet drawn by	Gepüeft checked by	Normgeprüft std. checked by	BB	10
=BR	+ER					8.30.11					

**Serial Numbers**

REF. NO.	MODEL: SERIAL #
1	10020310000177, 10020320000095, 10020330000083, 10020340000053, 10020350000188, 10020360100300
2	10020310000181, 10020320000100, 10020330000092, 10020340000056, 10020350000196, 10020360100317
3	10020310000235, 10020320000158, 10020330000114, 10020340000082, 10020350000220, 10020360100357
4	10020310000244, 10020320000158, 10020330000114, 10020340000085, 10020350000227, 10020360100360
5	10020310000280, 10020320000163, 10020330000137, 10020340000112, 10020350000271, 10020360100459, 10020370000182, 10020410000047, 10020420000001
6	10020310000349, 10020320000253, 10020330000148, 10020340000130, 10020350000337, 10020360100557
7	10020310000369, 10020320000275, 10020330000153, 10020340000144, 10020350000358, 10020360000591



**THANK YOU!**  
**MERCI! DANKE! ¡GRACIAS!**



Registrieren Sie Ihr Produkt und profitieren Sie von vielen Vorteilen.

Register your product and benefit from many advantages.

Enregistrez votre produit et bénéficiez de nombreux avantages.

Registre su producto y aproveche de muchas ventajas.

**[www.kaercher.com/welcome](http://www.kaercher.com/welcome)**



Bewerten Sie Ihr Produkt und sagen Sie uns ihre Meinung.

Rate your product and tell us your opinion.

Évaluer votre produit et dites-nous votre opinion.

Reseñe su producto y díganos su opinión

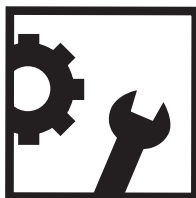

**[www.kaercher.com/dealersearch](http://www.kaercher.com/dealersearch)**

**Alfred Kärcher SE & Co. KG**  
Alfred-Kärcher-Str. 28-40  
71364 Winnenden (Germany)  
Tel.: +49 7195 14-0  
Fax: +49 7195 14-2212

